

HP Deskjet D4200 Printer series

HP Photosmart Software Help



Hewlett-Packard Company notices

The information contained in this document is subject to change without notice.

All rights reserved. Reproduction, adaptation, or translation of this material is prohibited without prior written permission of Hewlett-Packard, except as allowed under copyright laws.

The only warranties for HP products and services are set forth in the express warranty statements accompanying such products and services. Nothing herein should be construed as constituting an additional warranty. HP shall not be liable for technical or editorial errors or omissions contained herein.

Acknowledgements

Microsoft, MS, MS-DOS, and Windows are registered trademarks of Microsoft Corporation.

TrueType is a U.S. trademark of Apple Computer, Inc.

Adobe, AdobeRGB, and Acrobat are trademarks of Adobe Systems Incorporated.

Terms and conventions

The following terms and conventions are used in this user's guide.

Terms

The HP Deskjet printer is also referred to as the **HP Deskjet**, **HP printer**, or **printer**.

Cautions and warnings

A **Caution** indicates possible damage to the HP Deskjet printer or to other equipment. For example:

 **CAUTION:** Do not touch the print cartridge ink nozzles or copper contacts. Touching these parts will result in clogs, ink failure, and bad electrical connections.

A **Warning** indicates possible harm to you or to others. For example:

 **WARNING!** Keep both new and used print cartridges out of the reach of children.

Accessibility

Your HP printer provides a number of features that make it accessible for people with disabilities.

Visual

The printer software is accessible for users with visual impairments or low vision through the use of Windows accessibility options and features. It also supports most assistive technology such as screen readers, Braille readers, and voice-to-text applications. For users who are color blind, colored buttons and tabs used in the software and on the HP printer have simple text or icon labels that convey the appropriate action.

Mobility

For users with mobility impairments, the printer software functions can be executed through keyboard commands. The software also supports Windows accessibility options such as StickyKeys, ToggleKeys, FilterKeys, and MouseKeys. The printer doors, buttons, paper trays, and paper guides can be operated by users with limited strength and reach.

Support

For more details about the accessibility of this product and HP's commitment to product accessibility, visit HP's Web site at: www.hp.com/accessibility.

Contents

1	Welcome	5
2	Special features	7
3	Get started	
	The printer at a glance	8
	Buttons and lights	10
	Power button and light	11
	Print Cartridge Status lights	12
	Photosmart Essential button	13
	Resume button and light	14
	Front USB port lights	14
	Cancel icon	15
	Paper trays	15
	Unfold the paper trays	16
	Input tray	17
	Paper guide	17
	Output tray	17
	Fold the paper trays	18
	Print cartridges	19
	Replace print cartridges	20
	Ink-backup mode	20
	Ink-backup mode output	21
	Exit ink-backup mode	21
4	Connect the printer	
	USB	22
5	Print using the Photosmart Essential button	
	About the Photosmart Essential button	23
	About the HP Photosmart Software	23
6	Print photos using the front USB port	
	About the front USB port	24
	Print photos from the front USB port	24
	About the front USB port lights	25
7	Print photos	
	Print borderless photos	27
	Print photos with a border	29
	HP Real Life Technologies photo fix	31
	Photo print cartridge	31
	Advanced color settings	32
	Exif Print	32
	Store and handle photo paper	33
	Save money when printing photos	33

Share photos with friends and family	34
Other photo projects	34
8 Print other documents	
Print e-mail	35
Print documents	36
Print letters	37
Print envelopes	38
Print postcards	39
Print hagaki cards	40
Print index cards and other small media	41
Print labels	42
Print CD/DVD tattoos	43
Print transparencies	44
Print brochures	45
Print greeting cards	46
Print booklets	47
Print posters	49
Print iron-on transfers	50
9 Printing tips	
Print a test page	52
Printing shortcuts	52
Create printing shortcuts	53
Fast/Economical printing	53
Select a paper type	54
Select a specific paper type	54
Change the print speed or quality	54
Print resolution	55
Maximum dpi	55
Print in grayscale	56
Set the page order	56
Set a custom paper size	56
Print multiple pages on a single sheet of paper	57
Resize a document	57
Print preview	57
Two-sided printing	58
Bound two-sided documents	58
10 Printer software	
Make the HP Deskjet the default printer	60
Set default print settings	60
Printer Properties dialog box	61
What's This? help	62
Ink Status window	62
Download printer software updates	63

11 Maintenance

Install print cartridges64

 Print cartridge combinations64

 Selection numbers64

 Printing with one print cartridge65

 Installation instructions65

Align print cartridges67

Automatically clean print cartridges67

Calibrate print quality68

View estimated ink levels68

Maintain the printer body69

Remove ink from your skin and clothing69

Manually clean print cartridges69

Maintain print cartridges70

 Print cartridge storage and handling71

 Print cartridge protector71

Printer Toolbox72

12 Troubleshooting

Error messages73

 Print cartridge error messages73

 Other error messages74

Installation problems74

Printer lights are on or flashing76

 What the flashing light means77

 Power light is flashing77

 Resume light is flashing78

 Both Power and Resume lights are flashing78

 Print Cartridge Status lights are on or flashing79

 Front USB port lights are flashing80

Printer does not print80

 Verify the following80

 Check the printer lights80

 Check the printer cable connection80

 Printer is stalled81

 If the printer still does not print82

Document prints slowly82

Print cartridge problems83

Paper problems86

 Paper jam86

 Out-of-paper message88

 Printer prints on multiple sheets at once88

Photos do not print correctly89

 Check the paper tray89

 Check the printer properties89

 Part of the photo is faded90

 Fading occurs on the edges of a photo90

 Fading occurs near the edges of a photo91

Problems with borderless documents	91
Borderless printing guidelines	91
Part of the photo is faded	93
Fading occurs on the edges of a photo	94
Fading occurs near the edges of a photo	94
Photo has an unwanted border	94
For most paper types	95
For photo paper with a tear-off tab	95
Print quality is poor	96
Document is misprinted	98
Front USB port problems	100
If you continue to have problems	101
A HP support	
Ink cartridge warranty information	102
Support process	102
HP support by phone	103
Phone support period	103
Placing a call	103
After the phone support period	103
B Order supplies	
Order paper or other media	104
Order print cartridges	104
Order other supplies	104
C Technical information	
Printer specifications	106
Environmental product stewardship program	106
Paper use	107
Plastics	107
Material safety data sheets	107
Recycling program	107
HP inkjet supplies recycling program	107
Energy consumption	107
Disposal of Waste Equipment by Users in Private Households in the European Union ..	108
Regulatory notices	109
FCC statement	109
LED indicator statement	109
Notice to users in Korea	109
VCCI (Class B) compliance statement for users in Japan	109
Notice to users in Japan about power cord	110
Index	111

1 Welcome

Welcome to the HP Deskjet D4200 Printer series Help. This guide primarily explains how to print photos from memory cards, digital cameras, and other USB devices. For details on how to use your computer and the printer together, see the following table and select an appropriate topic. You can also use the table of contents pane on the left to locate information.

 **NOTE:** For information about installing the software, see the Setup Guide that came with the printer.

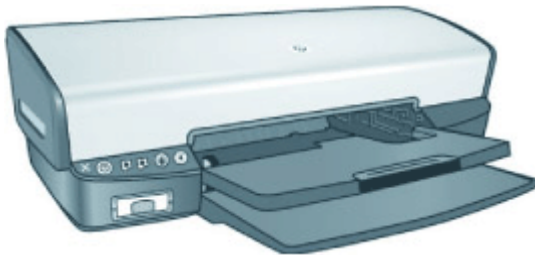

Section	Description
Special features	Learn about some of the printer's special features.
Get started	Learn how to operate the printer and use and replace the print cartridges.
Connect the printer	Learn how to connect the printer to your computer.
Print using the PhotoEssential button	Open the HP Photosmart Software and access the HP imaging features.
Print photos from a digital camera	Learn how to use the front USB port on the printer to transfer and print photos from a digital camera.
Print photos	Learn how to print photos, adjust the appearance of photos before you print, install a photo print cartridge, store and handle photo paper, and share photos with friends and family.
Print other documents	Learn how to print a variety of documents, including e-mail, greeting cards, envelopes, labels, posters, booklets, transparencies, and iron-on media.
Printing tips	Learn how to use printing shortcuts, select a paper type, change the print resolution, set the page order, print multiple pages on a single sheet, preview a document, and use two-sided printing.
Printer software	Learn how to make the HP Deskjet the default printer, set default print settings, and download printer software updates.
Maintenance	Learn how to install and care for print cartridges, view how much ink is left in a print cartridge, print a test page, and remove ink stains.

(continued)

Section	Description
HP support	Find out how to contact HP support.
Troubleshooting	Find a solution to a hardware or software problem.
Order supplies	Learn how to order supplies for the printer.
Specifications	Learn about the paper capacity, requirements, and other specifications for the printer.
HP inkjet supplies recycling program	Find out how to recycle print cartridges.

2 Special features

Congratulations! You have purchased an HP Deskjet printer that is equipped with several exciting features:

- **Borderless printing:** Use the entire page surface when printing [photos](#) and [brochures](#) with the borderless printing feature.
- **Six-ink upgradeable printing:** Enhance photo printing with a [photo print cartridge](#) (purchased separately).
- **Ink-backup mode:** Continue printing with one print cartridge when the other print cartridge has run out of ink. For information, see [Ink-backup mode](#).
- **Printing from a digital camera:** Transfer and print photos from a digital camera using the [front USB](#) port.
- **Print Cartridge Status display:** Know when a print cartridge is low on ink by viewing the [Print Cartridge Status lights](#).
- **Panoramic printing:** Print panoramic photos [with borders](#) or [without borders](#).
- **HP Vivera Inks:** Get true-to-life photo quality and exceptional fade resistance with vivid colors that last. HP Vivera Inks are specially formulated and scientifically tested for quality, purity and fade resistance.
- **Photosmart Essential button:** Use the [Photosmart Essential button](#) to open the HP Photosmart Software, which provides a fast and easy way to make prints of your photos.
- **CD/DVD Tattoos:** Personalize your CDs and DVDs by printing high-quality, low-cost [CD/DVD Tattoos](#). (This feature might not be available in your country/region.)

3 Get started

- [The printer at a glance](#)
- [Buttons and lights](#)
- [Paper trays](#)
- [Print cartridges](#)
- [Ink-backup mode](#)

The printer at a glance

Click the links below to learn about the printer features.

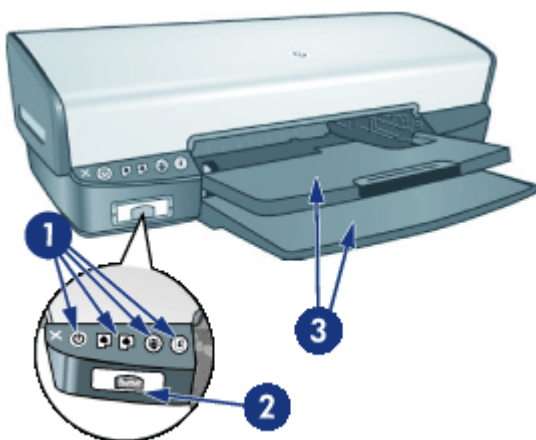

1	Buttons and lights
2	Front USB port
3	Paper trays

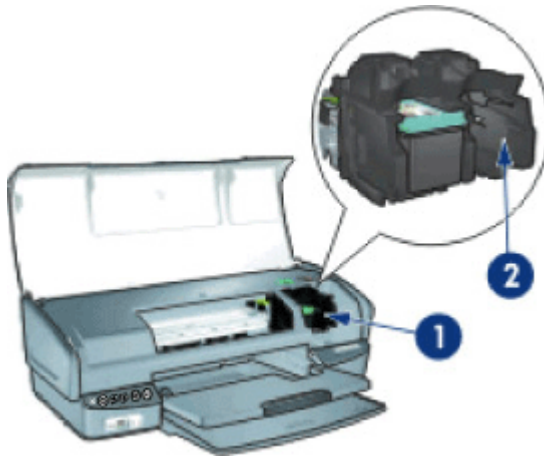

- | | |
|---|----------------------------------|
| 1 | Print cartridges |
| 2 | Ink-backup mode |

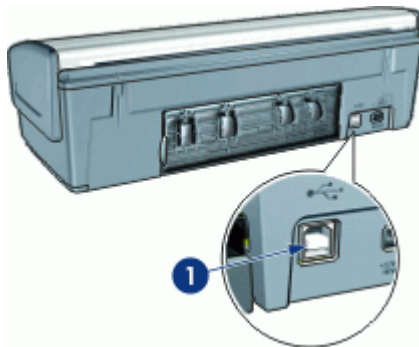

- | | |
|---|--------------------------|
| 1 | USB port |
|---|--------------------------|

Buttons and lights

Use the printer buttons to turn the printer on and off, cancel a print job, restart a job, and open HP Photosmart Software. The printer lights give you visual cues about the status of the printer.

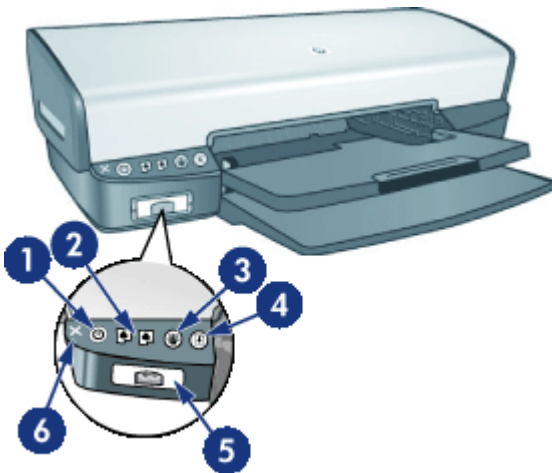

1	Power button and light
2	Print Cartridge Status lights
3	Photosmart Essential button
4	Resume button and light
5	Front USB port lights
6	Cancel icon

Power button and light

Use the Power button to turn the printer on and off. It can take a few seconds for the printer to turn on after you press the Power button.

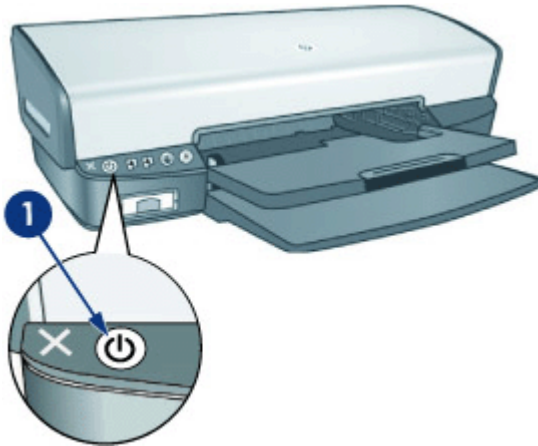

1	Power button and light
---	------------------------

The Power light flashes when the printer is processing.

△ **CAUTION:** Always use the Power button to turn the printer on and off. Using a power strip, surge protector, or a wall-mounted switch to turn the printer on and off might cause printer failure.

Print Cartridge Status lights

The Print Cartridge Status lights are located in the center of the control panel. For more information, see [Print cartridges](#).

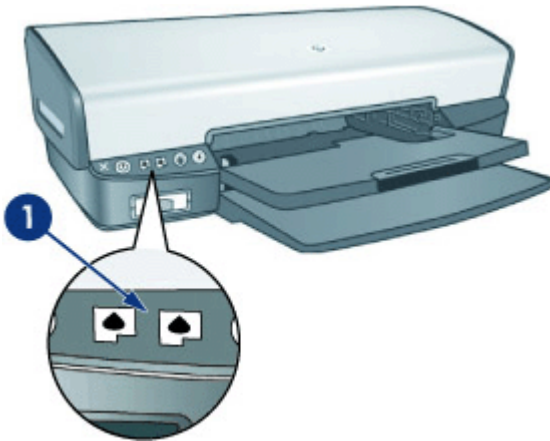

1	Print Cartridge Status lights
---	-------------------------------

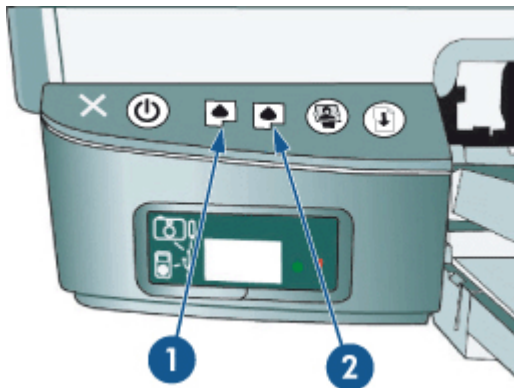

1	Tri-color print cartridge light
2	Black/Photo print cartridge light

1. The left status light represents the tri-color print cartridge, which is installed in the left side of the print cartridge cradle.
 - The light is on and solid when the tri-color print cartridge is low on ink.
 - The light flashes when the tri-color print cartridge needs to be serviced.
2. The right status light represents the black or the photo print cartridge. For more information, see [Photo print cartridge](#). One of these print cartridges is installed in the right side of the print cartridge cradle.
 - The light is on and solid when the black or photo print cartridge is low on ink.
 - The light flashes when the black or photo print cartridge needs to be serviced.

Photosmart Essential button

Use the Photosmart Essential button to open the HP Photosmart Software.

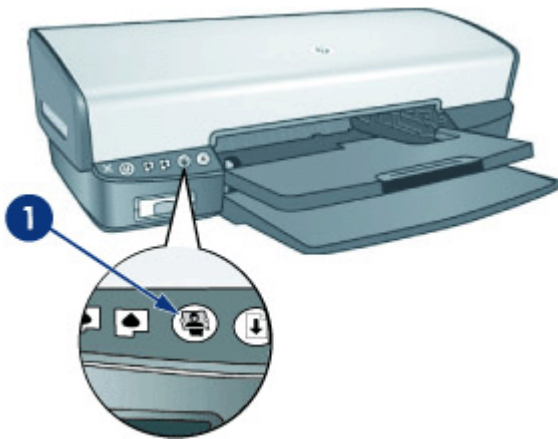

1	Photosmart Essential button
---	-----------------------------

The HP Photosmart Software provides a fast and easy way to make prints of your photos. It also provides access to other basic HP imaging software features, such as saving, viewing, and sharing your photos.

Resume button and light

The Resume light flashes when an action is required, such as loading paper or clearing a paper jam. When the problem is solved, press the Resume button to continue printing.



1	Resume button and light
---	-------------------------

Front USB port lights

To transfer photos from a digital camera, external card reader, or USB flash drive, just plug the camera or other device into the printer's front USB port. You can then print the photos using HP Photosmart Software.

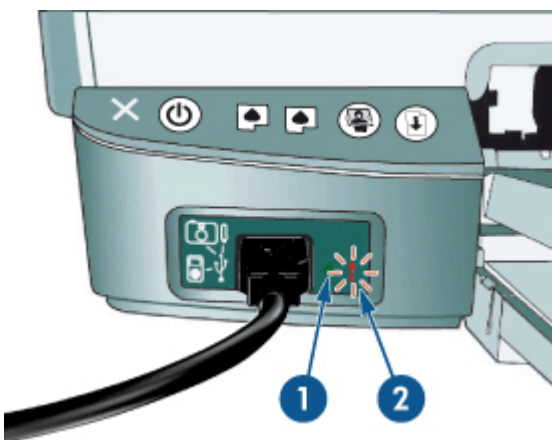

1	Connection light
2	Error light

When the camera is connected correctly, the Connection light is illuminated. The Connection light blinks green when printing from the camera. If the camera is not set to the correct mode for downloading photos, the Error light flashes.

 **NOTE:** You can also use the front USB port to download images from external card readers, USB flash drives, and other USB devices.

Cancel icon

The printer has a Cancel icon located to the left of the Power button. When the printer is busy, the Power button functions like a Cancel button.

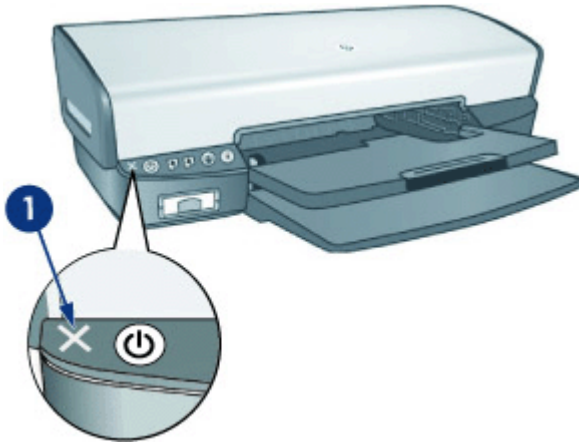

1	Cancel icon
---	-------------

Pressing the Power button during a print job or print cartridge alignment job cancels the job. Pressing the Power button when the printer is idle turns the printer off.

Paper trays

For information about the paper trays, select one of these topics.

- [Unfold the paper trays](#)
- [Input tray](#)
- [Paper guide](#)
- [Output tray](#)
- [Fold the paper trays](#)

Unfold the paper trays

To unfold the paper trays

1. Lower the input tray.

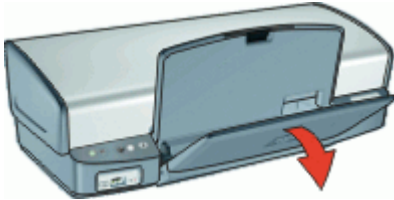

2. Lower the output tray.

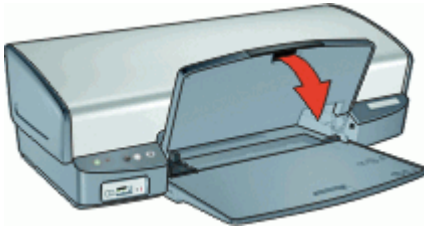

3. Pull out the output-tray extension.



Input tray

The input tray holds paper or other media.

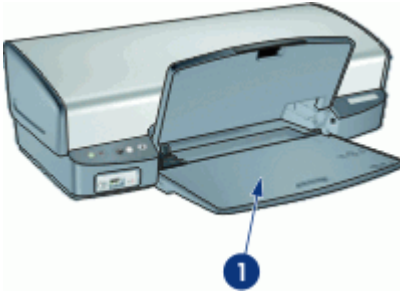

1	Input tray
---	------------

Paper guide

Print on different sizes of media by sliding the paper guide to the right or to the left.

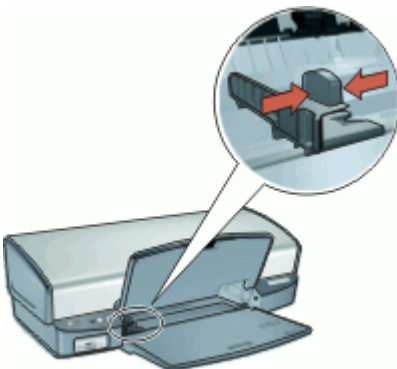

Output tray

Printed pages are deposited in the output tray.



1	Output tray
---	-------------

Raise the output tray to load paper or other media. Lower the output tray before printing. To prevent paper from falling out of the output tray, pull out both sections of the output-tray extension. If you are printing in the Fast Draft mode, raise the output-tray extension stop.

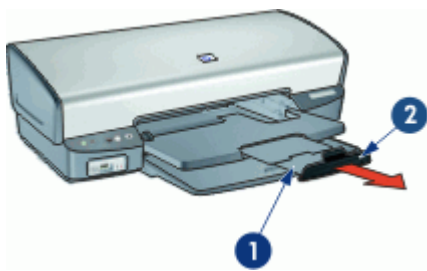

1	Second section of output-tray extension
2	Output-tray extension stop

Fold the paper trays

To fold the paper trays

1. Remove paper or other media from the paper trays.
2. If the output-tray extension stop is raised, lower it and then push the second section of the output-tray extension in.



3. Push the first section of the output-tray extension into the output tray.



4. Raise the output tray.

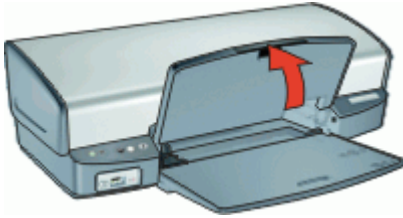

5. Raise the input tray.

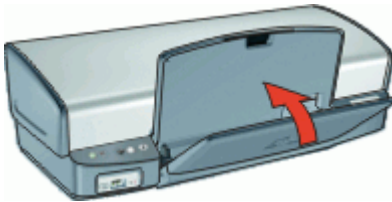

Print cartridges

Three print cartridges can be used with the printer.



1	Black print cartridge
2	Tri-color print cartridge
3	Photo print cartridge

For information about using the print cartridges, see the following topics:

- [Use print cartridges](#)
- [Replace print cartridges](#)

Use print cartridges

The print cartridges can be used in the following ways:

- **Everyday printing:** Use the black and tri-color print cartridges for everyday print jobs.
- **Quality color photos:** For more vibrant colors when printing color photographs or other special documents, remove the black print cartridge and install a photo print cartridge. The photo print cartridge, in combination with the tri-color print cartridge, provides you with virtually grain-free photos.

Replace print cartridges

When buying print cartridges, look for the print cartridge selection number.

You can find the selection number in three places:

- Selection number label: Look at the label on the print cartridge that you are replacing.



1	Selection number label
---	------------------------

- Printer documentation: For a list of print cartridge selection numbers, see the reference guide that came with the printer.
- Print Cartridge Ordering Information dialog box: For a list of print cartridge selection numbers, open the printer [Toolbox](#), click the **Estimated Ink Level** tab, and then click the **Print Cartridge Information** button.

If a print cartridge runs out of ink, the printer can operate in ink-backup mode. For more information, see [Ink-backup mode](#).

For information about installing a replacement print cartridge, see [Installation instructions](#).

Ink-backup mode

In the ink-backup mode, the printer operates with only one print cartridge. The ink-backup mode is initiated when a print cartridge is removed from the print cartridge cradle.

 **NOTE:** When the printer operates in ink-backup mode, a message is displayed on screen. If the message is displayed and two print cartridges are installed in the printer, verify that the protective piece of plastic tape has been removed from each print cartridge. When plastic tape covers the print cartridge contacts, the printer cannot detect that the print cartridge is installed.

To remove plastic tape from a print cartridge

- ▲ Hold the print cartridge so that the copper strips are on the bottom and facing toward the printer, and then carefully remove the plastic tape.

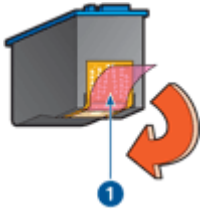

1	Remove plastic tape
---	---------------------

△ **CAUTION:** Do not touch the print cartridge ink nozzles or copper contacts. Touching these parts will result in clogs, ink failure, and bad electrical connections. Do not remove the copper strips. They are required electrical contacts.

For more information about ink-backup mode, see the following topics:

- [Ink-backup mode output](#)
- [Exit ink-backup mode](#)

Ink-backup mode output

Printing in ink-backup mode slows the printer and affects the quality of printouts.

Installed print cartridge	Result
Black print cartridge	Colors print as grayscale.
Tri-color print cartridge	Colors print but black is grayed and is not a true black.
Photo print cartridge	Colors print as grayscale.

 **NOTE:** HP does not recommend using the photo print cartridge for ink-backup mode.

Exit ink-backup mode

Install two print cartridges in the printer to exit ink-backup mode.

For information about installing a print cartridge, see [Installation instructions](#).

4 Connect the printer

- [USB](#)

USB

The printer connects to the computer with a universal serial bus (USB) cable.

 **NOTE:** For best printing performance, use a USB 2.0 compatible cable.

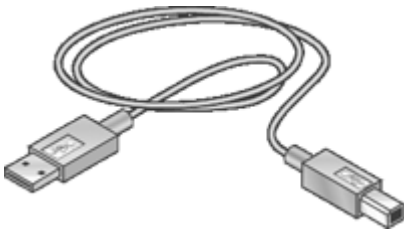

For instructions about connecting the printer with a USB cable, see the Setup Guide that came with the printer.

 **NOTE:** A USB cable might not be packaged with your printer.

5 Print using the Photosmart Essential button

To quickly print photos, use the Photosmart Essential button.

- [About the Photosmart Essential button](#)
- [About the HP Photosmart Software](#)

About the Photosmart Essential button

The Photosmart Essential button is located on the front panel of the printer. When you press the button, the HP Photosmart Software is opened on your computer.

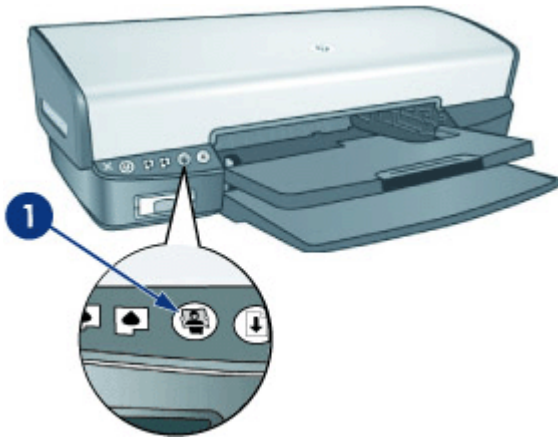

1 | Photosmart Essential button

About the HP Photosmart Software

The HP Photosmart Software provides a fast and easy way to make prints of your photos. It also provides access to other basic HP imaging software features, such as saving, viewing, and sharing your photos.

 **NOTE:** If the HP Photosmart Software is not installed on your computer, a message is displayed when you press the Photosmart Essential button. For more information, see [I pressed the Photosmart Essential button, but nothing happens.](#)

For more information on using the HP Photosmart Software:

- Check the **Contents** panel on the left. Look for the **HP Photosmart Software Help contents** book at the top.
- If you do not see the **HP Photosmart Software Help contents** book at the top of the **Contents** panel, access the software help through the HP Solution Center.

6 Print photos using the front USB port

You can transfer photos from a digital camera, external card reader, or USB flash drive to your computer, and then print them. For more information, check the following topics:

- [About the front USB port](#)
- [Print photos from the front USB port](#)
- [About the front USB port lights](#)

About the front USB port

To transfer photos from a digital camera, external card reader, or USB flash drive, just plug the camera or other device into the printer's front USB port. You can then print the photos using HP Photosmart Software.



In order to print photos from the front USB port you need a USB cable that is compatible with your camera. HP recommends that you use a cable that is less than 3 meters long.



Print photos from the front USB port

 **NOTE:** To print using these instructions, the HP Photosmart Software must be installed on your computer.

To print from the front USB port

1. Load photo paper into the printer.
For instructions about loading photo paper, click one of the following options:
 - [Print borderless photos](#)
 - [Print photos with a border](#)
2. Connect your camera or other USB device to the front USB port using a USB cable. The green Connection light should be illuminated. For more information, see [About the front USB port lights](#).
3. Turn on your camera or device, and then set it to transfer photos.
If you do not know how to set the camera or device to transfer photos, see the documentation that came with the camera or device.
4. Start the HP Photosmart Software.
If you attached an HP digital camera to the front USB port, the HP Photosmart Software starts automatically.
If you attached a non-HP digital camera or another device, press the Photosmart Essential button on the printer.
5. Before printing photos you must transfer them to your computer's hard drive. Do one of the following:
 - If the photos are displayed at the top of the HP Photosmart Software dialog box, click **Save**, and then follow the onscreen instructions.
 - If the photos are not displayed at the top of the HP Photosmart Software dialog box, click **Browse photos**. Follow the onscreen instructions to locate the photos. Click **Save**, and then follow the onscreen instructions.After the files are transferred the HP Photosmart Software dialog box is displayed.
6. Click **Print**, and then follow the onscreen instructions.

For more information on using the HP Photosmart Software, see the HP Photosmart Software Help.

About the front USB port lights

The lights on the front USB port let you know if the device is connected correctly and if the photos are transferring.

- When the camera is connected correctly, the Connection light is illuminated. The Connection light blinks green when photos are transferring.
- If the camera is not set to the correct mode for transferring photos, the Error light flashes.

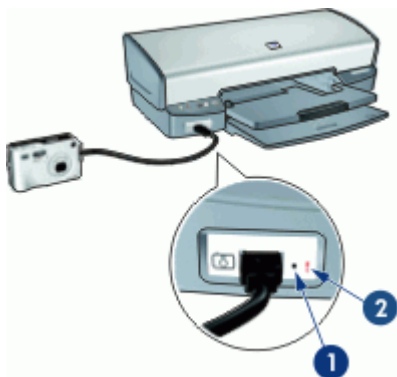

1	Connection light
2	Error light

7 Print photos

The printer software offers several features that make printing digital photos easier and improve photo quality.

Learn how to print photos



Print a [borderless photo](#).



Print a photo with a [border](#).

Learn how to perform other photo printing tasks

- Use the [photo print cartridge](#) for great colors and virtually grain-free photos.
- Improve printed colors with [advanced color settings](#).
- Print an [Exif Print-formatted](#) photo if you have Exif Print-enabled software.
- Prevent photo paper from curling by following the [photo paper storage and handling guidelines](#).
- Use HP Everyday Photo Paper to [save money and ink](#) when printing photos.
- Share photos with [friends and family](#).
- Learn how to create [other photo projects](#).

Print borderless photos

Use borderless printing to print to the edges of certain paper types and to print on a range of paper sizes—from 4 x 6 inch photo paper to a 210 x 594 mm (8.5 x 23.4 inch) custom photo size.

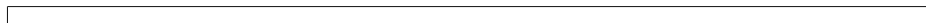

Guidelines

- For high-quality results, use a [photo print cartridge](#) in combination with the tri-color print cartridge.
- Do not print borderless photos in ink-backup mode. Always have two print cartridges installed in the printer.
For more information, see [Ink-backup mode](#).
- Open the file in a software program such as HP Photosmart Software and resize the photo. Ensure that the size corresponds to the paper size that you want to use.
- For maximum fade resistance, use HP Premium Plus Photo Paper.
- Verify that the photo paper that you are using is flat. For information about preventing photo paper from curling, see the [photo paper storage instructions](#).
- Do not exceed the input tray capacity: 30 sheets of photo paper.

Prepare to print

1. Raise the output tray.
2. Slide the paper guide all the way to the left.
3. Verify that the photo paper is flat.
4. Place the photo paper in the right side of the input tray. The side to be printed on should face down and the short edge should point towards the printer.
If you are using photo paper that has a tear-off tab, verify that the tab is pointing away from the printer.
5. Push the paper into the printer until it stops.
6. Slide the paper guide firmly against the edge of the paper.

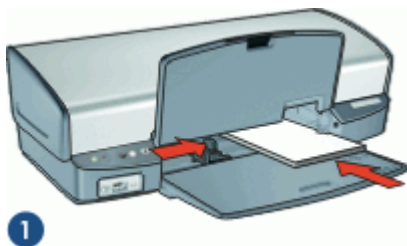

1	Small photos
---	--------------

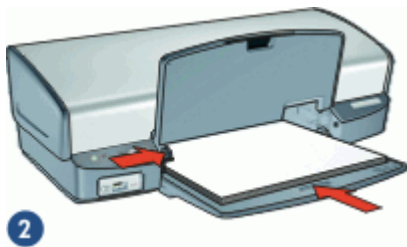

2	Large photos
---	--------------

7. Lower the output tray.

Print

 **NOTE:** If your software program includes a photo printing feature, follow the instructions that are provided with the software program. Otherwise, follow these instructions.

1. Open the photo in a software program that allows editing, such as HP Photosmart Software.
2. Open the [Printer Properties dialog box](#).
3. Click the **Printing Shortcuts** tab.

4. In the **Printing Shortcuts** list, click **Photo Printing-Borderless**, and then select the following options:
 - **Print Quality: Normal or Best**

 **NOTE:** For maximum dpi quality, go to the **Features** tab, and then click **Maximum dpi** in the **Print Quality** drop-down list.

 - **Paper Type:** An appropriate photo paper type
 - **Paper Size:** An appropriate borderless photo paper size
 - **Orientation: Portrait or Landscape**
5. If necessary, change the [HP Real Life Technologies photo fix](#) setting.
6. Select any other print settings that you want, and then click **OK**.
If you printed on photo paper with a tear-off tab, remove the tab to make the document completely borderless.

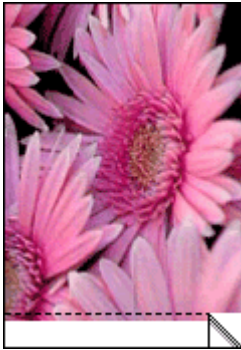

Use the [What's This? help](#) to learn about the features that appear in the Printer Properties dialog box.

Print photos with a border

Guidelines

- For high-quality results, use a [photo print cartridge](#) in combination with the tri-color print cartridge.
- For maximum fade resistance, use HP Premium Plus Photo Paper.
- Open the file in a software program such as HP Photosmart Software and assign the photo size. Ensure that the size corresponds to the paper size on which you want to print the photo.
- Verify that the photo paper that you are using is flat. For information about preventing photo paper from curling, see the [photo paper storage instructions](#).
- Do not exceed the input tray capacity: 30 sheets of photo paper.



Prepare to print

1. Raise the output tray.
2. Slide the paper guide all the way to the left.
3. Verify that the photo paper is flat.
4. Place the photo paper in the right side of the input tray. The side to be printed on should face down and the short edge should point towards the printer.

 **NOTE:** Some paper sizes might extend beyond the edge of the input tray.

5. Push the paper into the printer until it stops.
6. Slide the paper guide firmly against the edge of the paper.

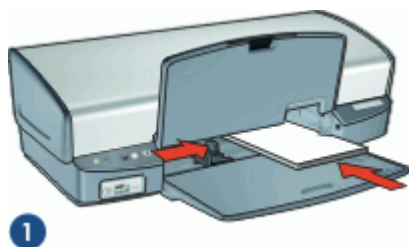

1

1 | Small photos

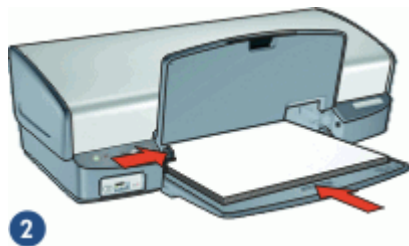

2

2 | Large photos

7. Lower the output tray.

Print

 **NOTE:** If your software program includes a photo printing feature, follow the instructions that are provided with the software program. Otherwise, follow these instructions.

1. Open the photo in a software program that allows editing, such as HP Photosmart Software.
2. Open the [Printer Properties dialog box](#).
3. Click the **Printing Shortcuts** tab.

4. In the **Printing Shortcuts** list, click **Photo Printing-with white borders**, and then select the following options:

- **Print Quality: Normal or Best**



NOTE: For maximum dpi quality, go to the **Features** tab, and then click **Maximum dpi** in the **Print Quality** drop-down list.

- **Paper Type:** An appropriate photo paper type
 - **Paper Size:** An appropriate photo paper size
 - **Orientation: Portrait or Landscape**
5. If necessary, change the [HP Real Life Technologies photo fix](#) setting.
 6. Select any other print settings that you want, and then click **OK**.

Use the [What's This? help](#) to learn about the features that appear in the Printer Properties dialog box.

HP Real Life Technologies photo fix

HP Real Life Technologies enhance the quality of your printed photos.

In most cases, you do not need to change the **Basic** default print setting. The Basic setting sharpens the images that you print, and improves the quality and clarity of low resolution images, such as those downloaded from the Internet.

You can change the setting to **Full** if the images that you print are under exposed or over exposed, contain dark areas or red eye, or have colors that appear washed out.

You can also select the **Off** setting if you prefer to edit the image manually in a software program such as HP Photosmart Software.

To change the HP Real Life Technologies setting

1. Open the [Printer Properties dialog box](#).
2. Click the **Features** tab.
3. In the HP Real Life Technologies **Photo fix** drop-down list, select the appropriate setting for the photo you are printing.

Photo print cartridge

The photo print cartridge, when used in conjunction with the tri-color print cartridge, provides virtually grain-free photos. It offers exceptional fade resistance for photos that are printed on HP Premium Plus Photo Paper.



The photo print cartridge can be purchased separately if it is not included with your printer.

To install the photo print cartridge

- ▲ To install the photo print cartridge, remove the black print cartridge from the printer, and then install the photo print cartridge in the right side of the print cartridge cradle.

 **NOTE:** To learn how to install a print cartridge, see [Installation instructions](#). To protect a print cartridge when it is not in the printer, follow the [Maintain print cartridges](#) guidelines.

To use the photo print cartridge

1. Open the [Printer Properties dialog box](#).
2. Click the **Printing Shortcuts** tab.
3. In the **Printing Shortcuts** list, click either **Photo Printing-Borderless** or **Photo Printing-with white borders**.
4. In the **Print Quality** drop-down list, click **Normal** or **Best**.

 **NOTE:** For maximum dpi quality, go to the **Features** tab, and then click **Maximum dpi** in the **Print Quality** drop-down list.

5. In the **Paper Type** drop-down list, select the appropriate photo paper type.
6. Select any other print settings that you want, and then click **OK**.

Advanced color settings

Use the **More color options** dialog box to adjust how printed colors appear in your photos.

Adjusting these settings causes the printed colors to differ from the colors that appear on your computer monitor.

To specify advanced color settings

1. Open the [Printer Properties dialog box](#).
2. Click the **Color** tab, and then click the **More color options** button.
The More color options dialog box is displayed.
3. You can adjust the following settings:
 - Adjust the **Brightness**, **Saturation**, and **Color Tone** to affect how overall colors are printed.
 - Adjust the **Cyan**, **Magenta**, **Yellow**, and **Black** sliders to specify the level of each color that is used in printing.

 **NOTE:** When you adjust color settings, the changes are reflected in the Preview box.

4. After specifying the color settings, click **OK**.
5. Select any other print settings that you want, and then click **OK**.

Exif Print

Exif Print (Exchangeable Image File Format 2.2) is an international digital imaging standard that simplifies digital photography and enhances printed photos. When a photo is taken with an Exif Print-enabled digital camera, Exif Print captures information such as

exposure time, type of flash, and color saturation, and stores it in the image file. The printer software then uses this information to automatically perform image-specific enhancements to create outstanding photos.

To print Exif Print-enhanced photos, you must have the following items:

- A digital camera that supports Exif Print
- Exif Print-enabled photo software, such as HP Photosmart Software

To print Exif Print-enhanced photos

1. Open the photo in an Exif Print-enabled software program that allows editing, such as HP Photosmart Software.
2. Open the [Printer Properties dialog box](#).
3. Click the **Features** tab.
4. In the **Paper Type** drop-down list, click **More**, and then select the appropriate photo paper type.
5. In the **Print Quality** drop-down list, click **Normal**, **Best**, or **Maximum dpi**.
6. Select any other print settings that you want, and then click **OK**.
The printer software automatically optimizes the printed image.

Store and handle photo paper

Follow these instructions to maintain the quality of HP brand photo paper.

Storage

- Keep unused photo paper in a sealed plastic bag. Store the packaged photo paper on a flat surface in a cool place.
- When you are ready to print, remove only the paper that you plan to use immediately from the plastic bag. When you have finished printing, return any unused photo paper to the plastic bag.
- Do not leave unused photo paper in the paper tray. The paper might start to curl, which can reduce the quality of your photos.

Handling

- Always hold photo paper by its edges. Fingerprints on photo paper can reduce print quality.
- If the corners of the photo paper curl more than 10 mm (0.4 inch), flatten the paper by putting it in the storage bag, and then gently bending it in the opposite direction of the curl until the paper lies flat.
Photo paper should be flat before it is printed on.

Save money when printing photos

To save money and ink when printing photos, use HP Everyday Photo Paper and set the print quality to **Normal**.

HP Everyday Photo Paper is designed to create quality photos with less ink.



NOTE: For higher-quality photos, use HP Premium Plus Photo Paper and set the print quality to **Best** or **Maximum dpi**.

Share photos with friends and family

If you have installed the HP Photosmart Software, you can use HP Photosmart Share to easily share images by e-mail without the use of large file attachments. HP Photosmart Share lets you:

- Select and share images
- Create online albums to share, organize, or store photos
- Order professionally processed prints online (availability varies by country/region)



NOTE: You must have Internet access to use HP Photosmart Share.

For more information, see the HP Photosmart Share Help.

Other photo projects

The HP Photosmart Software coordinates the functions of HP imaging devices: scanners, cameras, printers, and all-in-one devices. Depending on the devices you have installed and their capabilities, you can quickly and easily organize, edit, and share digital images.

If you performed the default typical installation of the printer software, you also installed the HP Photosmart Software. With HP Photosmart Software you can easily:

- Organize, edit, and share digital images in creative ways
- Print photos and digital images
- Transfer images from a camera or memory card
- View images as a slide show
- Edit images
- Create photo album pages and flyers
- Share photos with friends and family

For more information on using the HP Photosmart Software:

- Check the **Contents** panel on the left. Look for the **HP Photosmart Software Help contents** book at the top.
- If you do not see the **HP Photosmart Software Help contents** book at the top of the **Contents** panel, access the software help through the HP Solution Center.

8 Print other documents



E-mail



Documents



Letters



Envelopes



Postcards



Hagaki cards



Index cards



Labels



CD/DVD tattoos



Transparencies



Brochures



Greeting cards



Booklets



Posters



Iron-on transfers

Printing tips: Minimize your cost and effort while maximizing the quality of your printouts with [printing tips](#).

Printer software: Learn about the [printer software](#).

Print e-mail

Guidelines

Do not exceed the input tray capacity: 100 sheets of plain paper.

Prepare to print

1. Raise the output tray.
2. Slide the paper guide all the way to the left.
3. Place plain paper in the right side of the input tray. The side to be printed on should face down.
4. Push the paper into the printer until it stops.

5. Slide the paper guide firmly against the edge of the paper.

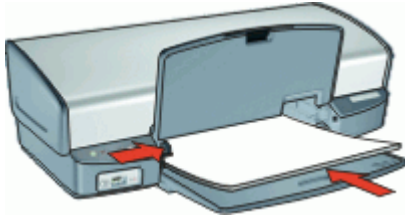

6. Lower the output tray.

Print

1. Open the [Printer Properties dialog box](#).
2. Click the **Printing Shortcuts** tab.
3. In the **Printing Shortcuts** list, click **General Everyday Printing** or **Fast/Economical Printing**, and then specify the following print settings:
 - **Paper Type: Plain paper**
 - **Paper Size:** An appropriate paper size
4. Select any other print settings that you want, and then click **OK**.

Use the [What's This? help](#) to learn about the features that appear in the Printer Properties dialog box.

Print documents

Guidelines

- For draft documents, use [Fast/Economical printing](#).
- Save paper with [two-sided printing](#).
- Do not exceed the input tray capacity: 100 sheets of paper.

Prepare to print

1. Raise the output tray.
2. Slide the paper guide all the way to the left.
3. Place plain paper in the right side of the input tray. The side to be printed on should face down.
4. Push the paper into the printer until it stops.

 **NOTE:** Depending on the paper size, the paper might extend over the edge of the tray.

5. Slide the paper guide firmly against the edge of the paper.

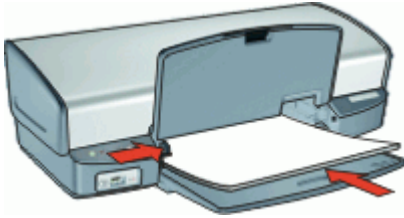

6. Lower the output tray.

Print

1. Open the [Printer Properties dialog box](#).
2. Click the **Printing Shortcuts** tab.
3. In the **Printing Shortcuts** list, click **General Everyday Printing**, and then specify the following print settings:
 - **Paper Type: Plain paper**
 - **Paper Size:** An appropriate paper size
4. Select the following print settings:
 - **Print Quality** if you want a print quality other than Normal
 - **Print On Both Sides** if you want to print on both sides of the paper
For more information, see [Two-sided printing](#).
5. Select any other print settings that you want, and then click **OK**.

Use the [What's This? help](#) to learn about the features that appear in the Printer Properties dialog box.

Print letters

Guidelines

- For information about printing an envelope for your letter, see [envelopes](#).
- Do not exceed the input tray capacity: 100 sheets of paper.

Prepare to print

1. Raise the output tray.
2. Slide the paper guide all the way to the left.
3. Place plain paper in the right side of the input tray. The side to be printed on should face down.

 **NOTE:** If you are using letterhead paper, the letterhead should face down and point toward the printer.

4. Push the paper into the printer until it stops.

5. Slide the paper guide firmly against the edge of the paper.

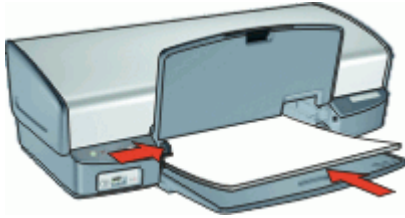

6. Lower the output tray.

Print

1. Open the [Printer Properties dialog box](#).
2. Click the **Printing Shortcuts** tab.
3. In the **Printing Shortcuts** list, click **Presentation Printing**, and then specify the following print settings:
 - **Paper Type: Plain paper**
 - **Paper Size:** An appropriate paper size
4. Select any other print settings that you want, and then click **OK**.

Use the [What's This? help](#) to learn about the features that appear in the Printer Properties dialog box.

Print envelopes

Guidelines

- Avoid using envelopes that have the following features:
 - Clasps or windows
 - Thick, irregular, or curled edges
 - Shiny or embossed coatings
 - Wrinkles, tears, or other damage
- You can print a single envelope or multiple envelopes.
- Align the envelope edges before inserting the envelopes in the input tray.
- Do not exceed the input tray capacity: 10 envelopes.



Prepare to print

1. Raise the output tray, and then remove all paper from the input tray.
2. Slide the paper guide all the way to the left.
3. Place the envelopes in the right side of the tray. The side to be printed on should face down. The flap should be on the left side.
4. Push the envelopes into the printer until they stop.

5. Slide the paper guide firmly against the edge of the envelopes.



6. Lower the output tray.

Print

1. Open the [Printer Properties dialog box](#).
2. Click the **Features** tab, and then select the following print settings:
 - **Paper Type: Plain paper**
 - **Size:** An appropriate envelope size
3. Select any other print settings that you want, and then click **OK**.

Use the [What's This? help](#) to learn about the features that appear in the Printer Properties dialog box.

Print postcards

Guidelines

Do not exceed the input tray capacity: 30 postcards.

Prepare to print

1. Raise the output tray, and then remove all paper from the input tray.
2. Slide the paper guide all the way to the left.
3. Place the cards in the right side of the input tray. The side to be printed on should face down and the short edge should point toward the printer.
4. Push the cards into the printer until they stop.
5. Slide the paper guide firmly against the edge of the cards.

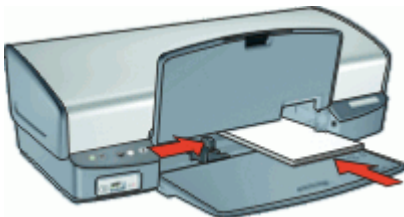

6. Lower the output tray.

Print

1. Open the [Printer Properties dialog box](#).
2. Click the **Features** tab, and then specify the following print settings:
 - **Paper Type:** Click **More**, click **Specialty Papers**, and then select an appropriate card type.
 - **Print Quality:** **Normal** or **Best**
 - **Size:** An appropriate card size
3. Select any other print settings that you want, and then click **OK**.

Use the [What's This? help](#) to learn about the features that appear in the Printer Properties dialog box.

 **NOTE:** If an out-of-paper message is displayed, see [Out-of-paper message](#) for help in resolving the problem.

Print hagaki cards

(Japan only)

Guidelines

Do not exceed the input tray capacity: 30 hagaki cards

Prepare to print

1. Raise the output tray, and then remove all paper from the input tray.
2. Slide the paper guide all the way to the left.
3. Place the cards in the right side of the input tray. The side to be printed on should face down and the short edge should point toward the printer.
4. Push the cards into the printer until they stop.
5. Slide the paper guide firmly against the edge of the cards.

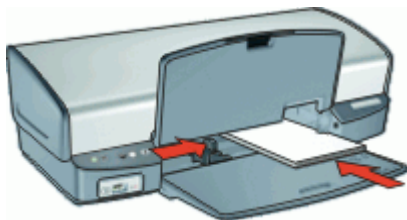

6. Lower the output tray.

Print

1. Open the [Printer Properties dialog box](#).
2. Click the **Features** tab, and then specify the following print settings:
 - **Paper Type:** Click **More**, click **Hagaki**, and then select an appropriate hagaki card type.
 - **Print Quality:** **Normal** or **Best**
 - **Size:** An appropriate hagaki card size
3. Select any other print settings that you want, and then click **OK**.

Use the [What's This? help](#) to learn about the features that appear in the Printer Properties dialog box.

 **NOTE:** If an out-of-paper message is displayed, see [Out-of-paper message](#) for help in resolving the problem.

Print index cards and other small media

Guidelines

Do not exceed the input tray capacity: 30 cards.

Prepare to print

1. Raise the output tray, and then remove all paper from the input tray.
2. Slide the paper guide all the way to the left.
3. Place the cards in the right side of the input tray. The side to be printed on should face down and the short edge should point toward the printer.
4. Push the cards into the printer until they stop.
5. Slide the paper guide firmly against the edge of the cards.

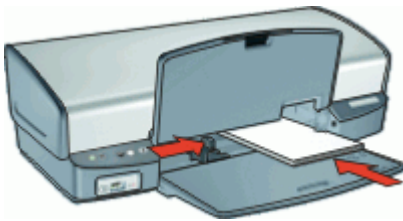

6. Lower the output tray.

Print

1. Open the [Printer Properties dialog box](#).
2. Click the **Features** tab, and then specify the following print settings:
 - **Paper Type:** **Plain paper**
 - **Size:** An appropriate card size
3. Select any other print settings that you want, and then click **OK**.

Use the [What's This? help](#) to learn about the features that appear in the Printer Properties dialog box.

 **NOTE:** If an out-of-paper message is displayed, see [Out-of-paper message](#) for help in resolving the problem.

Print labels

Guidelines

- Use only paper, plastic, or clear labels that are designed specifically for inkjet printers.
- Use only full sheets of labels.
- Avoid using labels that are sticky, wrinkled, or pulling away from the protective backing.
- Do not exceed the input tray capacity: 20 sheets of labels (use only Letter or A4-size sheets).

Prepare to print

1. Raise the output tray, and then remove all paper from the input tray.
2. Slide the paper guide all the way to the left.
3. Fan the edges of the label sheets to separate them, and then align the edges.
4. Place the label sheets in the right side of the input tray. The label side should face down.
5. Push the sheets into the printer until they stop.
6. Slide the paper guide firmly against the edge of the sheets.

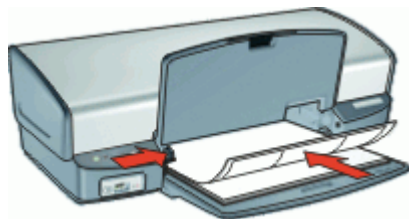

7. Lower the output tray.

Print

 **NOTE:** If your software program includes a label printing feature, follow the instructions that are provided with the software program. Otherwise, follow the instructions below.

1. Open the [Printer Properties dialog box](#).
2. Click the **Printing Shortcuts** tab.

3. In the **Printing Shortcuts** list, click **General Everyday Printing**, and then specify the following print settings:
 - **Paper Type: Plain paper**
 - **Paper Size:** An appropriate paper size
4. Click **OK**.

Use the [What's This? help](#) to learn about the features that appear in the Printer Properties dialog box.

Print CD/DVD tattoos

 **NOTE:** This feature might not be available in your country/region.

Guidelines

- See the instructions that are included with the CD/DVD tattoo for the most current printing tips.
- To avoid damaging the printer, do not feed a CD/DVD tattoo through the printer more than once.
- Make sure the CD/DVD tattoo covers the entire backing sheet with no exposed spaces. Separating any part of the CD/DVD tattoo from the protective backing sheet before printing could damage the printer.
- Avoid using a CD/DVD tattoo that is pulling away from the protective backing, or that is wrinkled, curled, or damaged in any way.
- Do not exceed the input tray capacity: 1 sheet of CD/DVD tattoo paper.

Prepare to print

1. Raise the output tray, and then remove all paper from the input tray.
2. Slide the paper guide all the way to the left.
3. Place one sheet of CD/DVD tattoo paper in the right side of the input tray. The side to be printed on should face down.
4. Push the paper into the printer until it stops.
5. Slide the paper guide firmly against the edge of the paper.

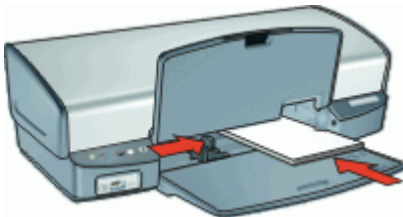

6. Lower the output tray.

Print

1. Open the [Printer Properties dialog box](#).
2. Click the **Features** tab, and then specify the print settings in the order shown below:
 - **Size:** 5x7in.
 - **Paper Type:** Click **More**, click **Specialty Papers**, and then click **HP CD/DVD Tattoo**.
 - **Print Quality:** **Best**

 **NOTE:** If you are using the HP Photosmart Essential Software, click the **Advanced** tab. Then expand **Printer Features**, and set **Mirror Image** to **On**.

3. Select any other print settings that you want, and then click **OK**.

Use the [What's This? help](#) to learn about the features that appear in the Printer Properties dialog box.

Print transparencies

Guidelines

- For great results, use HP Premium Inkjet Transparency Film.
- Do not exceed the input tray capacity: 30 transparencies.

Prepare to print

1. Raise the output tray, and then remove all paper from the input tray.
2. Slide the paper guide all the way to the left.
3. Place the transparencies in the right side of the tray. The side to be printed should face down and the adhesive strip should face up and toward the printer.
4. Carefully push the transparencies into the printer until they stop, so that the adhesive strips do not catch on one another.
5. Slide the paper guide firmly against the edge of the transparencies.

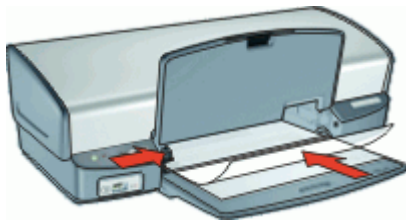

6. Lower the output tray.

Print

1. Open the [Printer Properties dialog box](#).
2. Click the **Printing Shortcuts** tab.

3. In the **Printing Shortcuts** list, click **Presentation Printing**, and then specify the following print settings:
 - **Paper Type:** Click **More**, and then select an appropriate transparency film.
 - **Paper Size:** An appropriate paper size
4. Select any other print settings that you want, and then click **OK**.

Use the [What's This? help](#) to learn about the features that appear in the Printer Properties dialog box.

Print brochures

Guidelines

- Do not print borderless brochures in ink-backup mode. Always have two print cartridges installed in the printer.
For more information, see [Ink-backup mode](#).
- Open the file in a software program and assign the brochure size. Ensure that the size corresponds to the paper size on which you want to print the brochure.
- Do not exceed the input tray capacity: 20 sheets of brochure paper.

Prepare to print

1. Raise the output tray.
2. Slide the paper guide all the way to the left.
3. Place the paper in the right side of the input tray. The side to be printed on should face down.
4. Push the paper into the printer until it stops.
5. Slide the paper guide firmly against the edge of the paper.

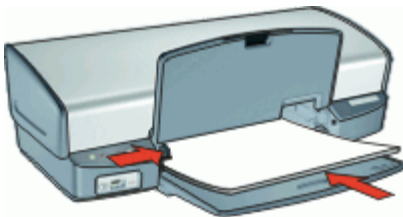

6. Lower the output tray.

Print

1. Open the [Printer Properties dialog box](#).
2. Click the **Features** tab.
3. If you are printing brochures without borders, select the **Borderless Printing** check box.

4. Specify the following print settings:
 - **Print Quality:** **Best**
 - **Paper Type:** Click **More**, and then select an appropriate HP inkjet paper.
 - **Orientation:** **Portrait** or **Landscape**
 - **Size:** An appropriate paper size
 - **Two-sided printing:** **Manual**For more information, see [Two-sided printing](#).

5. Click **OK** to print.

Use the [What's This? help](#) to learn about the features that appear in the Printer Properties dialog box.

Print greeting cards

Greeting cards

- Unfold prefolded cards, and then place them in the input tray.
- For great results, use HP Greeting Card Paper.
- Do not exceed the input tray capacity: 20 cards.

Prepare to print

1. Raise the output tray, and then remove all paper from the input tray.
2. Slide the paper guide all the way to the left.
3. Fan the edges of the greeting cards to separate them, and then align the edges.
4. Place the greeting cards in the right side of the input tray. The side to be printed on should face down.
5. Push the cards into the printer until they stop.
6. Slide the paper guide firmly against the edge of the cards.

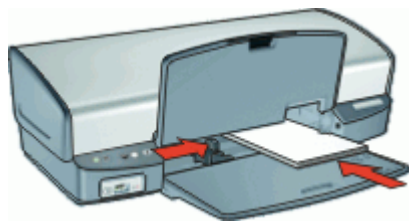

7. Lower the output tray.

Print

 **NOTE:** If your software program includes a greeting card printing feature, follow the instructions that are provided with the software program. Otherwise, follow the instructions below.

1. Open the [Printer Properties dialog box](#).
2. Click the **Features** tab, and then specify the following print settings:
 - **Print Quality: Normal**
 - **Paper Type:** Click **More**, and then select an appropriate card type.
 - **Size:** An appropriate card size
3. Select any other print settings that you want, and then click **OK**.

Use the [What's This? help](#) to learn about the features that appear in the Printer Properties dialog box.

Print booklets

Booklet printing automatically arranges and resizes the pages of a document so that when the document is folded into a booklet, the page order is correct.

For example, when a four-page booklet is printed on both sides of the paper, the pages are reordered and printed like this:

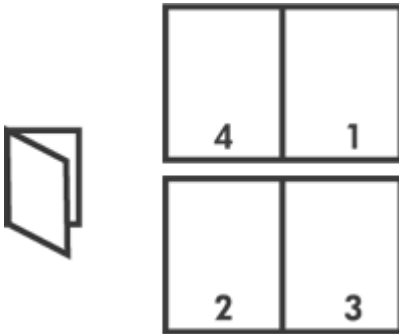

Guidelines

Do not exceed the input tray capacity: 100 sheets of paper.

Prepare to print

1. Raise the output tray.
2. Slide the paper guide all the way to the left.
3. Place plain paper in the right side of the input tray. The side to be printed on should face down.
4. Push the paper into the printer until it stops.

5. Slide the paper guide firmly against the edge of the paper.

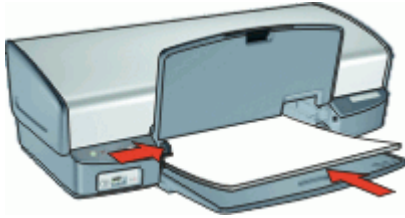

6. Lower the output tray.

Print

1. Open the [Printer Properties dialog box](#).
2. Click the **Printing Shortcuts** tab.
3. In the **Printing Shortcuts** list, click **Two-sided (Duplex) Printing**.
4. In the **Print On Both Sides** drop-down list, select one of the following binding options:
 - **Left Edge Booklet**
 - **Right Edge Booklet**
5. Select any other print settings that you want, and then click **OK**.
6. When prompted, reload the printed pages in the paper tray as shown below.



7. Click **Continue** to finish printing the booklet.

Use the [What's This? help](#) to learn about the features that appear in the Printer Properties dialog box.

Print posters

Guidelines

- For poster printing, sections of the poster are automatically arranged on individual sheets that can be taped together. After the sections of a poster have been printed, trim the edges of the sheets and tape the sheets together.



- Do not exceed the input tray capacity: 100 sheets of paper.

Prepare to print

1. Raise the output tray.
2. Slide the paper guide all the way to the left.
3. Place plain paper in the right side of the input tray. The side to be printed on should face down.
4. Push the paper into the printer until it stops.
5. Slide the paper guide firmly against the edge of the paper.

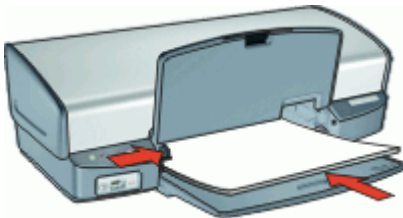

6. Lower the output tray.

Print

1. Open the [Printer Properties dialog box](#).
2. Click the **Features** tab, and then specify the following print settings:
 - **Paper Type: Plain paper**
 - **Orientation: Portrait or Landscape**
 - **Size:** An appropriate paper size
3. Click the **Advanced** tab, and then click **Printer Features**.

4. In the **Poster Printing** drop-down list, select the number of sheets for the poster.
5. Click the **Select Tiles** button.
6. Check that the number of tiles that are selected matches the number of sheets for the poster, and then click **OK**.
7. Select any other print settings that you want, and then click **OK**.

Use the [What's This? help](#) to learn about the features that appear in the Printer Properties dialog box.

Print iron-on transfers

Guidelines

- When printing a mirror image, the text and the pictures are horizontally reversed from what is displayed on the computer screen.



- Do not exceed the input tray capacity: 12 iron-on transfers.

Prepare to print

1. Raise the output tray, and then remove all paper from the input tray.
2. Slide the paper guide all the way to the left.
3. Place the iron-on transfer paper in the right side of the input tray. The side to be printed on should face down.
4. Push the paper into the printer until it stops.
5. Slide the paper guide firmly against the edge of the paper.

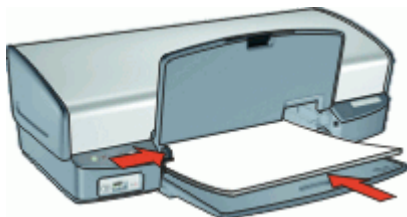

6. Lower the output tray.

Print

 **NOTE:** If your software program includes an iron-on transfer printing feature, follow the instructions that are provided with the software program. Otherwise, follow the instructions below.

1. Open the [Printer Properties dialog box](#).
 2. Click the **Features** tab, and then specify the following print settings:
 - **Print Quality:** **Normal** or **Best**
 - **Paper Type:** Click **More**, click **Specialty Papers**, and then click **HP Iron-On Transfer Paper**.
 - **Size:** An appropriate paper size
 3. Click the **Advanced** tab.
 4. Click **Printer Features**, and then set **Mirror Image** to **On**.
-

 **NOTE:** Some iron-on transfer software programs do not require you to print a mirror image.

5. Select any other print settings that you want, and then click **OK**.

Use the [What's This? help](#) to learn about the features that appear in the Printer Properties dialog box.

9 Printing tips

Check your printer

- [Connect the printer](#) to your computer.
- [Print a test page](#).

Save time

- Use the [Printing Shortcuts](#) tab.
- Set the [order](#) that the pages print.

Save money

- Use [Fast/Economical printing](#).
- Print [multiple pages on a single sheet of paper](#).
- Print in [grayscale](#).
- Print a [two-sided document](#).
- Use [HP Everyday Photo Paper](#) to save money and ink when printing photos.

Enhance the quality of prints

- [Preview](#) the document before printing it.
- Print on a [custom paper size](#).
- [Select a paper type](#).
- Change the [print speed and quality](#).
- View the [print resolution](#).
- Achieve the highest printing resolution with [Maximum dpi](#).
- [Resize](#) the document as needed.

Print a test page

You can print a test page to verify that the printer can print from the computer correctly.

To print a test page

1. Load Letter or A4 unused plain white paper in the paper tray.
2. Open the printer [Toolbox](#).
3. On the Device Services tab, click the **Print a Test Page** button.
The Print a Test Page dialog box is displayed.
4. Click the **Print Page** button.
Recycle or discard the test page.

Printing shortcuts

Use printing shortcuts to print with print settings that you use often. The printer software has several specially designed printing shortcuts that are available in the Printing Shortcuts list.

 **NOTE:** When you select a printing shortcut the appropriate printing options are automatically displayed. You can leave them as is or change them.

Use printing shortcuts

Use the Printing Shortcuts tab for the following print tasks:

- [General everyday printing](#)
- [Photo printing–borderless](#)
- [Photo printing–with white borders](#)
- [Fast/Economical printing](#)
- [Presentation printing](#)
- [Two-sided, duplex, printing](#)

You can also [create](#) your own printing shortcuts.

Create printing shortcuts

In addition to the printing shortcuts that are available in the Printing Shortcuts list, you can create your own printing shortcuts.

If you frequently print on transparency film, for example, you can create a printing shortcut by selecting the Presentation Printing shortcut, changing the paper type to HP Premium Inkjet Transparency Film, and then saving the modified shortcut under a new name; for example, Transparency Presentations. After creating the printing shortcut, simply select it when printing on transparency film rather than changing the print settings each time.

To create a printing shortcut

1. Open the [Printer Properties dialog box](#).
2. Click the **Printing Shortcuts** tab.
3. In the **Printing Shortcuts** list, click a printing shortcut.
The print settings for the selected printing shortcut are displayed.
4. Change the print settings to those you want in the new printing shortcut.
5. In the **Type new shortcut name here** box, type a name for the new printing shortcut, and then click **Save**.
The printing shortcut is added to the list.

To delete a printing shortcut

1. Open the [Printer Properties dialog box](#).
2. Click the **Printing Shortcuts** tab.
3. In the **Printing Shortcuts** list, click the printing shortcut that you want to delete.
4. Click **Delete**.
The printing shortcut is removed from the list.

 **NOTE:** Only the shortcuts that you have created can be deleted. The original HP shortcuts cannot be deleted.

Fast/Economical printing

Use Fast/Economical printing to produce draft-quality printouts quickly.

To use Fast/Economical printing

1. Open the [Printer Properties dialog box](#).
2. Click the **Printing Shortcuts** tab.
3. In the **Printing Shortcuts** list, click **Fast/Economical Printing**.
4. Specify the print settings that you want, and then click **OK**.

General Everyday printing

Use General Everyday printing to print documents quickly.

- [Documents](#)
- [E-mail](#)

Presentation printing

Use Presentation printing to print high-quality documents, including:

- [Letters](#)
- [Brochures](#)
- [Transparencies](#)

Select a paper type

To determine the paper type used for a printing job, select Automatic to use the automatic paper-type sensor or select a specific paper type.

Select a specific paper type

When printing a higher-quality document, HP recommends that you select a specific paper type.

To select a specific paper type

1. Open the [Printer Properties dialog box](#).
2. Click the **Features** tab.
3. Click **More** in the **Paper Type** drop-down list, and then select the paper type that you want to use.
4. Click **OK**.
5. Select any other print settings that you want, and then click **OK**.

Change the print speed or quality

The HP Deskjet automatically chooses a print quality and speed setting depending on the paper type setting you select. You can also change the print quality setting to customize the speed and quality of the print process.

Print quality settings

- **Fast Draft** produces draft-quality output at the fastest printing speed, while using the least amount of ink.
- **Fast Normal** produces higher quality output than the Fast Draft setting and prints more quickly than the Normal setting.
- **Normal** provides the best balance between print quality and speed and is appropriate for most documents.
- **Best** provides the best balance between high quality and speed and can be used for high quality prints. For most documents, the Best setting prints more slowly than the Normal setting.
- **Maximum dpi** optimizes the dots per inch (dpi) that the HP Deskjet prints. Printing in maximum dpi takes longer than printing with other settings and requires a large amount of disk space. For more information, see [Maximum dpi](#).

To select a print quality and speed

1. Open the [Printer Properties dialog box](#).
2. Click the **Features** tab.
3. In the **Paper Type** drop-down list, select the type of paper that you have loaded.
4. In the **Print Quality** drop-down list, select the appropriate quality setting for your project.

Print resolution

The printer software displays the print resolution in dots per inch (dpi). The dpi varies according to the paper type and print quality that you select in the printer software.

To view the print resolution

1. Open the [Printer Properties dialog box](#).
2. Click the **Features** tab.
3. In the **Paper Type** drop-down list, select the type of paper that you have loaded.
4. In the **Print Quality** drop-down list, select the appropriate print quality setting for your project.
5. Click the **Resolution** button to view the print resolution dpi.

Maximum dpi

Use maximum dpi mode to print high-quality, sharp images.

To get the most benefit from maximum dpi mode, use it to print high-quality images such as digital photographs. When you select the maximum dpi setting, the printer software displays the optimized dots per inch (dpi) that the HP Deskjet printer will print.

Printing in maximum dpi takes longer than printing with other settings and requires a large amount of disk space.

 **NOTE:** If a photo print cartridge is also installed, the print quality is enhanced. A photo print cartridge can be purchased separately if it is not included with the HP Deskjet.

To print in Maximum dpi mode

1. Open the [Printer Properties dialog box](#).
2. Click the **Features** tab.
3. In the **Paper Type** drop-down list, click **More**, and then select the appropriate paper type.
4. In the **Print Quality** drop-down list, click **Maximum dpi**.

 **NOTE:** To view the maximum dpi that the HP Deskjet printer will print, click **Resolution**.

5. Select any other print settings that you want, and then click **OK**.

Print in grayscale

To print in grayscale

1. Open the [Printer Properties dialog box](#).
2. Click the **Color** tab.
3. Click **Print In Grayscale**.
4. In the **Print In Grayscale** drop-down list, select an option.
5. Select any other print settings that you want, and then click **OK**.

Set the page order

The page order determines the order in which your multipage documents print.

To set the page order

1. Open the [Printer Properties dialog box](#).
2. Click the **Advanced** tab.
3. Click **Document Options**, and then click **Layout Options**.
4. Select one of the following **Page Order** options:
 - **Front to back:** Prints the first page of the document last. This setting saves time because you do not have to reorder the printed pages. It is the appropriate setting for most print jobs.
 - **Back to front:** Prints the last page of the document last.
5. Select any other print settings that you want, and then click **OK**.

Set a custom paper size

Use the **Custom Paper Size** dialog box to print on a special paper size.

 **NOTE:** This feature is not available for all paper types.

To define a custom paper size

1. Open the [Printer Properties dialog box](#).
2. Click the **Features** tab.

3. In the **Size** drop-down list, select **Custom**.
The Custom Paper Size dialog box is displayed.
4. In the **Name** box, type a name for the custom paper size.
5. In the **Width** and **Length** boxes, type the dimensions of the custom paper size.
The minimum and maximum dimensions are displayed beneath Width and Length.
6. Click the unit of measurement: **Inches** or **Millimeters**.
7. Click **Save** to save the custom paper size.
8. Click **OK** to exit the **Custom Paper Size** dialog box.
9. To use the custom paper size, select its name in the **Size** drop-down list.

Print multiple pages on a single sheet of paper

Use the printer software to print multiple pages of a document on a single sheet of paper. The printer software automatically resizes the document text and images to fit on the printed page.

To print multiple pages on a single sheet of paper

1. Open the [Printer Properties dialog box](#).
2. Click the **Features** tab.
3. In the **Pages Per Sheet** drop-down list, select the number of pages that you want to appear on each sheet of paper.
4. In the **Page Order** drop-down list, select a layout for the pages.
A preview of the page order is displayed at the top of the Features tab.
5. Select any other print settings that you want, and then click **OK**.

Resize a document

Use the printer software to print a document that is formatted for one paper size on another paper size. Doing this can be useful if you do not have the correct paper size available.

For example, if you have created a document that is formatted for letter-size paper, but you do not have any letter-size paper available, you can print the document on another paper size that is available.

To resize a document for a different paper size

1. Open the [Printer Properties dialog box](#).
2. Click the **Features** tab.
3. Click **Scale to paper size**, and then select the target paper size in the drop-down list.
The target paper size is the size of the paper on which you are printing, not the size for which the document was formatted.
4. Select any other print settings that you want, and then click **OK**.

Print preview

Use the print preview function to view a printout on your computer before printing a document. If the printout does not look correct, you can cancel the print job and adjust the print settings as needed.

To preview a printed document

1. Open the [Printer Properties dialog box](#).
2. Click the **Features** or the **Color** tab.
3. Select the **Show preview before printing** check box.
4. Select any other print settings that you want, and then click **OK**.
Before the document prints, a preview is displayed.
5. Do one of the following:
 - Click **OK** to print the document.
 - Click **Cancel** to cancel the print job. Adjust the print settings as needed before printing the document.

Two-sided printing

Use two-sided printing, also called duplexing, to print on both sides of the paper. Printing on both sides of the paper is not only economical, but environmentally conscious as well.

To print a two-sided document

1. Open the [Printer Properties dialog box](#).
2. Click the **Printing Shortcuts** tab.
3. In the **Printing Shortcuts** drop-down list, click **Two-sided (Duplex) Printing**.
4. In the **Print On Both Sides** drop-down list, click **Manually**.
5. Select any other print settings that you want, and then click **OK**.
The printer prints the odd-numbered pages first.
6. After the odd-numbered pages have been printed, reload the printed pages with the printed side facing up.



7. Click **Continue** to print the even-numbered pages.

To create a two-sided document with a binding, see [Bound two-sided documents](#).

Bound two-sided documents

If you want to bind printed pages into a book, you can adjust the print settings to accommodate the binding.

Bound two-sided documents can have a book binding (binding on the side) or a tablet binding (binding at the top). Book binding is the most common type of binding.

To print a two-sided document with a book binding

- ▲ Follow the [instructions](#) for basic two-sided printing.

To print a two-sided document with a tablet binding

1. Open the [Printer Properties dialog box](#).
2. Click the **Features** tab.
3. In the **Two-sided printing** drop-down list, click **Manual**.
4. Select the following check boxes:
 - **Flip Pages Up**
 - **Preserve Layout**
5. Select any other print settings that you want, and then click **OK**.
The printer prints the odd-numbered pages first.
6. After the odd-numbered pages have been printed, reload the printed pages, with the printed side facing up according to the document orientation, portrait or landscape.



Figure 9-1 Portrait



Figure 9-2 Landscape

7. Click **Continue** to print the even-numbered pages.

10 Printer software

- Make the HP Deskjet the [default printer](#).
- Set the [default print settings](#) for all documents.
- Use the [Printer Properties dialog box](#) to select printing options.
- Use the [What's This? help](#) to learn more about specific print settings.
- View the [Ink Status window](#) for the approximate ink level of each print cartridge.
- Download [printer software updates](#) for the latest features and improvements.

Make the HP Deskjet the default printer

You can set the HP Deskjet as the default printer to use from any software program. This means that the HP Deskjet is automatically selected in the printer drop-down list when you click **Print** from the **File** menu in a software program.

Windows 2000 users

1. On the Windows taskbar, click **Start**, point to **Settings**, and then click **Printers**.
2. Right-click the HP Deskjet icon, and then click **Set as Default Printer**.

Windows XP users

1. On the Windows taskbar, click **Start**, and then click **Printers and Faxes**.
2. Right-click the HP Deskjet icon, and then click **Set as Default Printer**.

Set default print settings

The HP Deskjet uses default print settings for all documents unless you specify other settings.

To save time when printing, set the default print settings to options that you use often. That way, you do not have to specify the options every time you use the printer.

To change the default print settings

1. Double-click the HP Digital Imaging Monitor icon on the right side of the Windows taskbar.



-
- | | |
|---|---------------------------------|
| 1 | HP Digital Imaging Monitor icon |
|---|---------------------------------|

The HP Solution Center is displayed.

2. In the HP Solution Center, click **Settings**, point to **Print Settings**, and then click **Printer Settings**.
3. Make changes to the print settings, and then click **OK**.

Printer Properties dialog box

The printer is controlled by software that is installed on your computer. Use the printer software, also known as the printer driver, to change the print settings for a document.

To change the print settings, open the Printer Properties dialog box.

 **NOTE:** The Printer Properties dialog box is also referred to as the Printing Preferences dialog box.

To open the Printer Properties dialog box

1. Open the file that you want to print.
2. Click **File**, click **Print**, and then click **Properties** or **Preferences**.
The Printer Properties dialog box is displayed.



NOTE: The path to the Printer Properties dialog box can vary depending on the software program you are using.

What's This? help

Use the [What's This? help](#) to learn about the features that you see on the Printer Properties dialog box.

What's This? help

Use What's This? help to learn more about the available printing options.

To use What's This? help

1. Move the cursor over the feature that you want to learn more about.
2. Click the right mouse button.
The What's This box is displayed.
3. Move the cursor over the **What's This?** box, and then click the left mouse button.
An explanation of the feature is displayed.

Ink Status window

The Ink Status window is displayed each time the printer prints a file. The window displays the approximate ink level of each print cartridge. To close the Ink Status window, click **Close**.



NOTE: This feature might not be available in your operating environment.

Print cartridge information and ordering

For print cartridge information and to link to HP's Web site for ordering print cartridges, click the **Print Cartridge Information** button.

Displaying the Ink Status window

If you do not want the Ink Status window to appear when you print, select the **Do not show this again** check box in the lower-left corner of the window.

If you previously chose not to show the Ink Status window but now want it to appear when you print, follow these steps:

1. For Windows 2000, click **Start**, and then click **Settings**. For Windows XP, click **Start**, and then click **Printers and Faxes**.
A list that includes the printers installed on your computer is displayed.
2. Highlight the printer name, and then right-click to display a list of options.
3. Click **Properties**.
The Printer Properties dialog box is displayed.
4. Click the **Device Settings** tab.
5. For **Display Ink Status Window**, click **On**, and then click **OK**.

Download printer software updates

Download the latest printer software update every few months to ensure you have the latest features and improvements.

To download a printer software update

1. Make sure you are connected to the Internet.
2. From the Windows **Start** menu, click **Programs** or **All Programs**, point to **HP**, and then click **HP Update**.
The HP Update window is displayed.
3. Click **Next**.
HP Update searches the HP Web site for printer software updates.
 - If the computer has the most recent version of the printer software installed, **No updates are available for your system at this time** is displayed in the HP Update window.
 - If the computer does not have the most recent version of the printer software installed, a list of options to download later versions of the software is displayed in the HP Update window.
4. If a software update is available, select the check box beside the update name.
5. Click **Install**.
6. Follow the onscreen instructions.

Download HP Photosmart Software

Installing the printer software update you download from the HP Web site does not update the HP Photosmart Software you might have installed on the computer. For information about updating the HP Photosmart Software, see the HP Photosmart Help.

11 Maintenance

- [Install print cartridges](#)
- [Align print cartridges](#)
- [Automatically clean print cartridges](#)
- [Calibrate print quality](#)
- [View estimated ink levels](#)
- [Maintain the printer body](#)
- [Remove ink from your skin and clothing](#)
- [Manually clean print cartridges](#)
- [Maintain print cartridges](#)
- [Printer Toolbox](#)

Install print cartridges

When you need to replace print cartridges, make sure you have the correct print cartridges for your printer, and then install them in the print cartridge cradle.

- [Print cartridge combinations](#)
- [Selection numbers](#)
- [Printing with one print cartridge](#)
- [Installation instructions](#)

Print cartridge combinations

Choose the right cartridge combination

Choose the best combination of cartridges for your print job:

- Everyday printing: Use a black cartridge along with a tri-color cartridge.
- Color photos: Use a photo cartridge along with a tri-color cartridge.

Always install the tri-color print cartridge in the left side of the print cartridge cradle.

Install the black or photo print cartridge in the right side of the print cartridge cradle.

Selection numbers

When buying replacement print cartridges, look for the print cartridge selection number.

You can find the selection number in three places:

- Selection number label: Look at the label on the print cartridge that you are replacing.

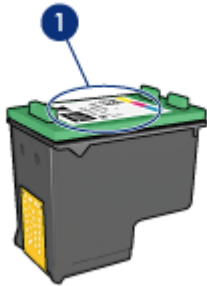

1	Selection number label
---	------------------------

- Printer documentation: For a list of print cartridge selection numbers, see the reference guide that came with the printer.
- Print Cartridge Information dialog box: For a list of print cartridge selection numbers, open the printer [Toolbox](#), click the **Estimated Ink Level** tab, and then click the **Print Cartridge Information** button.

Printing with one print cartridge

The printer can operate with only one print cartridge installed. For more information, see [Ink-backup mode](#).

Installation instructions

To install a print cartridge

1. Verify that the printer is turned on.
2. Load Letter or A4 plain, white paper in the paper tray.
3. Open the printer cover.
4. Wait until the print cartridge cradle moves to the right side of the printer and is idle and quiet.

5. Press down on the print cartridge, and then slide it out of the print cartridge cradle.

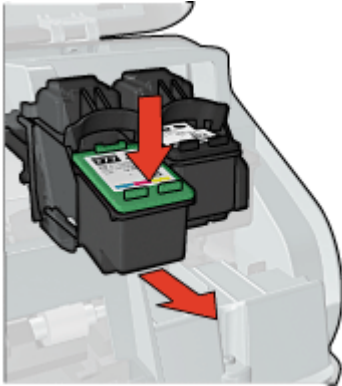

6. Remove the replacement print cartridge from its packaging and carefully remove the plastic tape. Hold the print cartridge so that the copper strips are on the bottom and facing toward the printer.

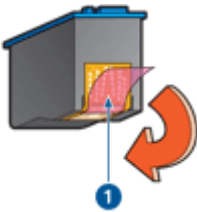

1	Remove plastic tape
---	---------------------

△ **CAUTION:** Do not touch the print cartridge ink nozzles or copper contacts. Touching these parts will result in clogs, ink failure, and bad electrical connections. Do not remove the copper strips. They are required electrical contacts.

- Slide the print cartridge at a slight upward angle into the cradle until the cartridge snaps into place.

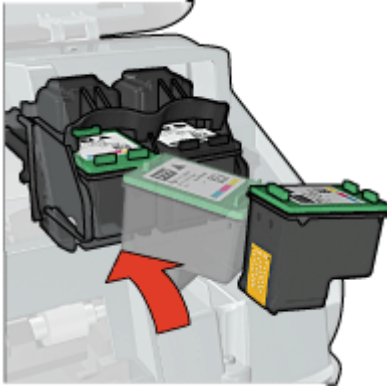

- Close the printer cover.
[Align](#) the print cartridges for optimum print quality.

For information about storing print cartridges, see [Maintain print cartridges](#).

For information about recycling empty print cartridges, see [HP inkjet supplies recycling program](#).

⚠ WARNING! Keep both new and used print cartridges out of the reach of children.

Align print cartridges

After installing a print cartridge, align the print cartridges to ensure the best print quality.

To align print cartridges

- Load Letter or A4 unused plain white paper in the paper tray.
- Open the printer [Toolbox](#).
- Click **Align the Print Cartridges**.
- Click **Align**, and then follow the onscreen instructions.
The HP Deskjet prints a test page, aligns the print cartridges, and calibrates the printer. Recycle or discard the test page.

Automatically clean print cartridges

If your printed pages are faded or if they contain ink streaks, the print cartridges might be low on ink or might need to be cleaned. For more information, see [View estimated ink levels](#).

If the print cartridges are not low on ink, clean the print cartridges automatically.

To clean the print cartridges

1. Open the printer [Toolbox](#).
2. Click **Clean the Print Cartridges**.
3. Click **Clean**, and then follow the onscreen instructions.

If your documents are still faded after cleaning, [manually clean the print cartridge contacts](#).

 **CAUTION:** Clean print cartridges only when necessary. Unnecessary cleaning wastes ink and shortens the life of the cartridge.

Calibrate print quality

Perform a print quality calibration if light or dark horizontal lines appear in documents that are printed with the tri-color and black print cartridges.

Before performing a print quality calibration, [clean the print cartridges](#), and then reprint the document. If the lines still occur, perform a print quality calibration.

To calibrate print quality

1. Load Letter or A4 unused plain white paper in the paper tray.
2. Verify that both a black and a tri-color [print cartridge](#) are installed in the printer.
3. Open the printer [Toolbox](#).
4. Click **Print Quality Calibration**.
5. Click **Continue**, and then follow the onscreen instructions.

View estimated ink levels

Follow these instructions to view the estimated ink levels of the print cartridges that are installed in the printer:

1. Open the printer [Toolbox](#).
2. Click the **Estimated Ink Level** tab.

 **NOTE:** If the print cartridges were used before being installed in the printer, or if they are not genuine HP cartridges or have been refilled, the estimated ink levels will not appear on the Estimated Ink Level tab.

The Estimated Ink Level tab also contains print cartridge ordering information. To view this information, click the **Print Cartridge Information** button.

 **NOTE:** Ink from the cartridges is used in the printing process in a number of different ways, including in the initialization process, which prepares the device and cartridges for printing, and in printhead servicing, which keeps print nozzles clear and ink flowing smoothly. In addition, some residual ink is left in the cartridge after it is used. For more information see www.hp.com/go/inkusage.

Maintain the printer body

Because the HP Deskjet ejects ink onto the paper in a fine mist, ink smudges will eventually appear.

To remove smudges, stains, or dried ink from the exterior

1. Turn off the HP Deskjet, and then disconnect the power cord.
2. Wipe the outside of the HP Deskjet with a soft cloth that has been lightly moistened with water.

△ **CAUTION:** Do not use any type of cleaning solution. Household cleaners and detergents might damage the printer finish. Keep all fluids away from the interior. Do not lubricate the metal rod on which the print cartridge cradle slides. Noise is normal when the cradle moves back and forth.

Remove ink from your skin and clothing

Follow these instructions to remove ink from your skin and clothing:

Surface	Remedy
Skin	Wash the area with an abrasive soap.
White fabric	Wash the fabric in <i>cold</i> water and use chlorine bleach.
Color fabric	Wash the fabric in <i>cold</i> water and use sudsy ammonia.

△ **CAUTION:** Always use cold water to remove ink from fabric. Warm or hot water can set the ink into the fabric.

Manually clean print cartridges

If the HP Deskjet is used in a dusty environment, a small amount of debris can accumulate on the print cartridge contacts. This debris can cause ink streaks on printed pages. The problem can be corrected by manually cleaning the print cartridge contacts.

You need the following items to clean the print cartridges:

- Distilled water (tap water can contain contaminants that can damage the print cartridge)
- Cotton swabs or other soft, lint-free material that will not stick to the print cartridge

Be careful not to get [ink on your hands or clothing](#) as you clean.

To prepare to clean

1. Open the HP Deskjet cover.
2. Wait until the print cartridge cradle moves to the right side of the HP Deskjet and is idle and quiet.
3. Remove the print cartridges and place them on a piece of paper, with the copper strips facing up.

△ **CAUTION:** Do not leave the print cartridges outside the HP Deskjet for more than 30 minutes.

To manually clean print cartridge contacts

1. Lightly moisten a cotton swab with distilled water and squeeze any excess water from the swab.
2. Gently wipe the print cartridge copper contacts with the cotton swab.

△ **CAUTION:** Do not touch the print cartridge ink nozzles. Touching the ink nozzles will result in clogs, ink failure, and bad electrical connections.



1	Ink nozzles (do not touch)
2	Copper contacts

3. Repeat this process until no ink residue or dust appears on the swab.
4. Insert the print cartridges in the HP Deskjet, and then close the cover. For more information, see [Installation instructions](#).

Maintain print cartridges

Follow these guidelines to maintain and store HP print cartridges and to ensure consistent print quality.

- [Print cartridge storage and handling](#)
- [Print cartridge protector](#)

Print cartridge storage and handling

Follow these guidelines to help maintain HP print cartridges and ensure consistent print quality:

- Install the cartridge on or before the **Install by** date, which is printed on the cartridge package.
- When you remove a photo print cartridge from the printer, store it in a print cartridge protector to prevent the ink from drying out. If you do not have a print cartridge protector, you can use an airtight plastic container to protect your print cartridge. For more information, see [Installation instructions](#).
- Keep all unused print cartridges in their original sealed packages until they are needed. Store print cartridges at room temperature (15° to 35° C or 59° to 95° F).
- Do not remove the plastic tape covering the ink nozzles until you are ready to install the print cartridge in the printer. If the plastic tape has been removed from the print cartridge, do not attempt to reattach it. Reattaching the tape damages the print cartridge.

△ **CAUTION:** Always turn the printer off with the Power button before you unplug the power cord or turn off a power strip. This allows the printer to store the print cartridges properly. When you store the printer, always leave the active print cartridges inside the printer.

Print cartridge protector

If you have purchased an HP photo print cartridge, you can store it in the protector that comes with the print cartridge. If you do not have a print cartridge protector, you can use an airtight plastic container to protect your print cartridge.

To insert the print cartridge into the print cartridge protector

- ▲ Slide the print cartridge at a slight angle into the protector, and snap it securely in place.



To remove the print cartridge from the print cartridge protector

1. Press down and back on the top of the protector to release the print cartridge.
2. Slide the print cartridge out of the protector.



△ **CAUTION:** Do not drop the print cartridge. Dropping the print cartridge can damage it.

Printer Toolbox

The printer Toolbox contains a number of useful tools to enhance the performance of the printer.

Use the printer Toolbox to perform the following tasks:

- [Align the print cartridges](#)
- [Calibrate print quality](#)
- [Clean the print cartridges](#)
- [Print a test page](#)
- [View estimated ink levels](#)

To open the printer Toolbox

1. Open the [Printer Properties dialog box](#).
2. Click the **Features** tab, and then click the **Printer services** button.
The Toolbox is displayed.

12 Troubleshooting

- [Error messages](#)
- [Installation problems](#)
- [Printer lights are on or flashing](#)
- [Printer does not print](#)
- [Document prints slowly](#)
- [Print cartridge problems](#)
- [Paper problems](#)
- [Photos do not print correctly](#)
- [Problems with borderless documents](#)
- [Print quality is poor](#)
- [Document is misprinted](#)
- [I pressed the Photosmart Essential button, but nothing happens](#)
- [Front USB port problems](#)
- [If you continue to have problems](#)

Error messages

If an error message displays on the computer screen, check the following topics for a solution:

- [Print cartridge error messages](#)
- [Other error messages](#)

Print cartridge error messages

If you receive a print cartridge error message, follow these directions.

Incorrect or missing print cartridge message

The printer can only print when the correct print cartridges are installed. If you receive a print cartridge error message, one or both of the print cartridges cannot be used in the printer.

To resolve the problem, follow the instructions in [Incorrect or missing print cartridge](#).

Print cartridge problem message

The printer cannot print if the print cartridges are faulty, or if they are not installed properly.

If you receive a message stating there is a problem with a print cartridge, follow the instructions in [Print cartridge is faulty or not installed properly](#) to resolve the problem.

"Print cartridge carriage is stalled" message

If the printer stalls while you are printing a document, follow the instructions in [Printer is stalled](#).

"Print cartridge is in the wrong slot" message

If you receive this error message, the print cartridge is installed in the wrong side of the print cartridge cradle. Follow the instructions in ["Print cartridge is in the wrong slot" message](#) to resolve the problem.

"Printing in ink-backup mode" message

If you receive this error message, follow the instructions in ["Printing in ink-backup mode" message](#).

Other error messages

If you receive an error message, follow these directions.

Out of paper message

If you receive an out of paper message, follow the guidelines in [Out-of-paper message](#).

"There was an error writing to USB port" message

The printer might not be receiving correct data from another USB device or USB hub. Connect the printer directly to the USB port on the computer.

"Two-way communication cannot be established" or "Printer not responding" message

The printer might not be able to communicate with the computer if the USB cable is too long.

If you receive this error message, make sure that the USB cable is not greater than 3 meters (approximately 9.8 feet) in length.



NOTE: For best printing performance, use a USB 2.0 compatible cable.

Installation problems

If the software installation program stops or fails, check the following topics for more information:

- [Installation program stops](#)
- ["Unknown Device" message displays](#)
- [Printer name does not appear](#)

If you continue to have problems, visit HP Technical Support at www.hp.com/support.

Installation program stops

Cause: If the installation program stops when it looks for new hardware, one of the following issues is causing a communication problem:

- The USB cable is old or defective.
- Software, such as an antivirus program, is running.
- Another device, such as a scanner, is connected to the computer.

Solution:

To resolve the problem

1. Make sure that no USB devices other than the printer, the keyboard, and the mouse are connected to the computer.
2. Disconnect and reconnect the USB cable.
3. Make sure that the printer is connected directly to a USB port on the computer (instead of through a USB hub).
4. If the installation program still does not locate the printer, replace the USB cable, and then continue to the next step.
5. Click **Cancel**, and then restart the computer.
6. Turn the printer off, and then disconnect the USB cable and power cord.
7. Quit any antivirus programs or other software programs that are running on the computer.



NOTE: To quit an antivirus program, follow the manufacturer's instructions.

8. Reinstall the printer software:
 - a. Insert the printer software CD into the drive.
 - b. Follow the onscreen instructions. When the installation program prompts you, connect the USB cable and the power cord to the printer, and then make sure that the printer is on.



NOTE: Do not connect the USB cable until you are told to do so.

- c. Follow the onscreen instructions to finish the installation.
9. Restart the antivirus program.

"Unknown Device" message displays

Cause: During installation, an "Unknown Device" message might be displayed when you connect a USB cable between the printer and the computer. A possible cause might be a defective USB cable.

Solution:



NOTE: This is not a problem if you are using Windows 2000. If you are using Windows 2000 and this message is displayed, you can continue with the software installation.

To resolve the problem

1. Disconnect the USB cable from the printer.
2. Disconnect the power cord from the printer.
3. Wait approximately 30 seconds.
4. Reconnect the power cord to the printer.
5. Reconnect the USB cable to the printer.
6. If the "Unknown Device" message is still displayed, replace the USB cable.

Printer name does not appear

Solution: If the printer software seems to install correctly, but the printer name does not appear in the list of printers when you click **Print** on the **File** menu or in the Printers folder in Control Panel, try reinstalling the printer software.

To reinstall the printer software

1. Quit any antivirus programs or other software programs that are running on the computer.

 **NOTE:** To quit an antivirus program, follow the manufacturer's instructions.

2. Uninstall the printer software:
 - a. Insert the printer software CD into the drive, and then follow the onscreen instructions.

 **NOTE:** If the installation program does not start automatically, click your CD drive letter in Windows Explorer, then double-click the setup.exe file. For example, double-click D:\setup.exe.

- b. When prompted, click **Remove All**.
 3. Reinstall the printer software:
 - a. Insert the printer software CD into the drive.
 - b. Follow the onscreen instructions to finish the installation.
 4. Restart the antivirus program.
-

Printer lights are on or flashing

- [What the flashing light means](#)
- [Power light is flashing](#)
- [Resume light is flashing](#)
- [Both Power and Resume lights are flashing](#)
- [Print Cartridge Status lights are on or flashing](#)
- [Front USB port lights are flashing](#)

What the flashing light means

The printer lights indicate the printer status.

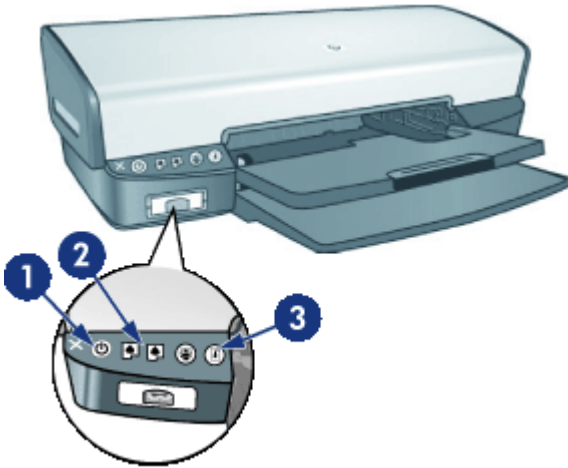

1	Power light
2	Print Cartridge Status lights
3	Resume light

Power light is flashing

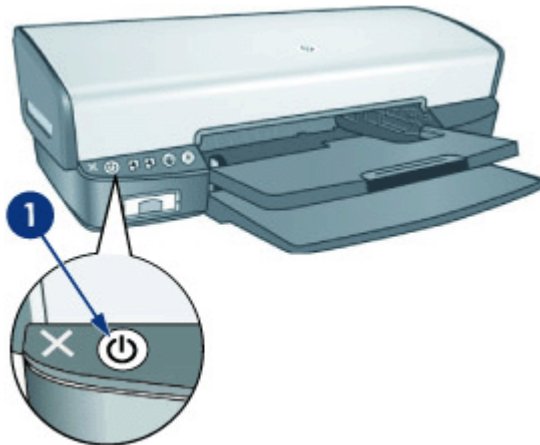

1	Power light
---	-----------------------------

If the Power light is flashing, the printer is preparing to print. The light stops flashing when the printer has received all data.

Resume light is flashing

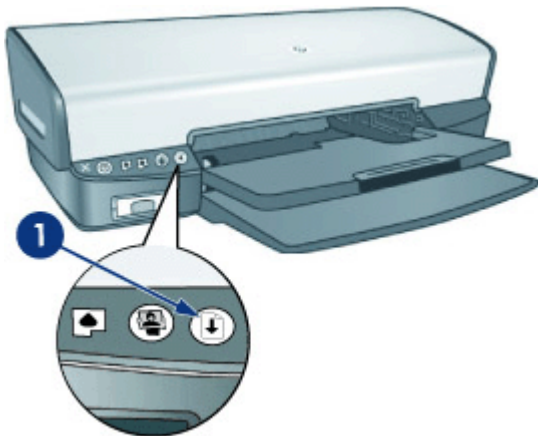

1	Resume light
---	--------------

If the Resume light is flashing, check the following conditions:

- The printer might be out of paper.
Place paper in the input tray, and then press the **Resume** button.
- There might be a paper jam.
For information about clearing a paper jam, see [Paper jam](#).
- The printer might be stalled.
For more information about correcting the problem, see [Printer is stalled](#).

Both Power and Resume lights are flashing

The printer might need to be restarted.

1. Press the **Power** button to turn off the printer, and then press the **Power** button to restart the printer.
Proceed to step 2 if the lights continue to flash.
2. Press the **Power** button to turn off the printer.
3. Disconnect the printer power cord from the electrical outlet.
4. Reconnect the printer power cord to the electrical outlet.
5. Press the **Power** button to turn on the printer.

Print Cartridge Status lights are on or flashing

The printer has two print cartridge status lights.

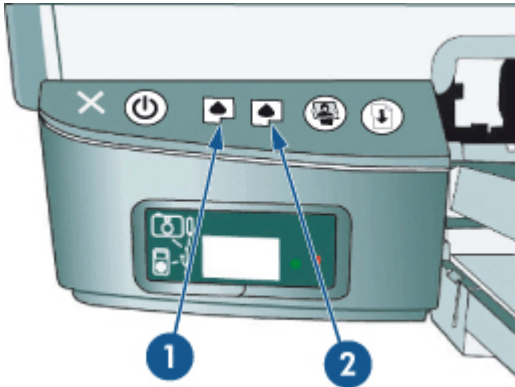

1. The left status light represents the tri-color print cartridge, which is installed in the left side of the print cartridge cradle.
2. The right status light represents the black or the photo print cartridge. One of these print cartridges is installed in the right side of the print cartridge cradle. For more information, see [Photo print cartridge](#).

If one or both Print Cartridge Status lights are on and not flashing

- Check to see if a print cartridge is [low on ink](#).
If a print cartridge is low on ink, consider replacing the print cartridge.
- If neither print cartridge is low on ink, press the **Resume** button. If the Print Cartridge Status light remains on, turn off, and then turn on the printer.

If one or both Print Cartridge Status lights are on and flashing

Verify that the correct print cartridges are installed. For more information, see [Installation instructions](#).

If you were printing a borderless document when the light started flashing, see [Borderless printing guidelines](#).

Otherwise, follow these steps:

1. Raise the printer cover, remove the print cartridge on the right, and then lower the cover.
2. Follow one of these steps:
 - If the Power light is flashing: Open the printer cover, replace the print cartridge that you removed, and then remove the other print cartridge. Proceed to step 3.
 - If the Power light is off: There is a problem with the print cartridge that you removed. Proceed to step 3.
3. [Manually clean](#) the print cartridge.
After cleaning the print cartridge, reinsert it into the printer.
If the light continues to flash, [replace the print cartridge](#).

Front USB port lights are flashing

If the front USB port lights are flashing, follow the instructions in [Front USB port lights are flashing](#).

Printer does not print

- [Verify the following](#)
- [Check the printer lights](#)
- [Check the printer cable connection](#)
- [Clear the print queue](#)
- [Printer is stalled](#)
- [If the printer still does not print](#)

Verify the following

Verify the following conditions if the printer is not printing:

- The printer is connected to the power source.
- The cable connections are secure.
- The printer is turned on.
- The print cartridges are the correct print cartridges for the printer and are properly installed.

For more information, see [Print cartridges](#) and [Installation instructions](#).

- The paper or other media is correctly loaded in the paper tray.
- The printer cover is closed.
- The rear access door is attached.

Check the printer lights

The printer lights indicate the printer status and alert you to potential problems.

For more information, see [Printer lights are on or flashing](#).

Check the printer cable connection

If your printer and computer are connected with a USB cable and the devices are not communicating with each other, try the following:

- Make sure the power cord is firmly connected to the printer and plugged into a power outlet.
- Check the USB cable. If you are using an older cable, it might not be working properly. If you experience problems, the USB cable might need to be replaced. Also verify that the cable does not exceed 3 meters (9.8 feet) in length.
- Check the connection from your printer to your computer. Verify that the USB cable is securely plugged into the USB port on the back of your printer. Make sure the other end of the USB cable is plugged into a USB port on your computer. After the cable is connected properly, turn your printer off and then on again.

- If you are connecting the printer through a USB hub, make sure the hub is turned on. If the hub is on, try connecting the printer directly to your computer.
- Try connecting the USB cable to another USB port on your computer. After you check the connections, try restarting your computer. Turn your printer off and then on again.

 **NOTE:** For best printing performance, use a USB 2.0 compatible cable.

Clear the print queue

Cause: When you start a print job, it is sent to a list called the “print queue.” If the printer stops printing before the job is complete, the print job might be stalled in the print queue.

Solution:

To resolve a print job that is stalled in the queue

1. For Windows 2000, click **Start**, click **Settings**, and then click **Printers**. For Windows XP, click **Start**, and then click **Printers and Faxes**.
2. Double-click the name of the HP Deskjet printer.
3. Click the **Printer** menu, and then click **Pause Printing**.
4. Click the **Printer** menu again, and then click **Cancel All Documents**.
5. Click **Yes** to confirm the cancellation.
6. Click the **Printer** menu, and then uncheck **Pause Printing**.
7. If there are still documents in the list, restart the computer.
8. After restarting, if there are still documents in the list, repeat steps 1 – 6.

After resolving a print job that is stalled in the print queue, the print queue still might not be clear. In that situation, you need to stop and then restart the print service.

To stop and restart the print service

1. For Windows 2000, click **Start**, click **Control Panel**, and then click **Administrative Tools**. For Windows XP, click **Start**, click **Control Panel**, click **Performance and Maintenance**, and then click **Administrative Tools**.
2. Double-click **Services**, and then double-click **Print Spooler**.
3. Click **Stop**, and then click **Start** to restart the print service.
4. Click **OK** to close the window.

Printer is stalled

If the printer stalls while printing a document, press the Resume button. If the printer does not start printing again, raise the printer cover, and then disconnect the power cable from the back of the printer.

 **CAUTION:** First, check for any loose or broken parts in the printer. If you find loose or broken parts, go to www.hp.com/support.

If there are no loose or broken parts, follow these steps:

1. Check for and remove any obstacles, such as packing tape or materials, that prevent the print cartridges from moving back and forth.
2. Make sure the print cartridges are installed securely in the print cartridge cradle. For more information, see [Installation instructions](#).
3. Make sure the tri-color print cartridge is installed in the left side of the cradle and the black or photo print cartridge is installed in the right side of the cradle.
4. Check for and clear any paper jam. For more information, see [Paper jam](#).
5. Lower the printer cover.
6. Connect the power cable to the back of the printer, and then turn on the printer.
 - If the Resume light is not flashing, continue printing the document.
 - If the Resume light is flashing, press the **Resume** button. If the light still flashes, repeat the steps.

If the printer still does not print

1. Select the topic below that best describes the problem:
 - [Paper jam](#)
 - [Out-of-paper message](#)
 - [Printer ejects paper](#)
 - [Printer is stalled](#)
2. If the printer still does not print, shut down, and then restart your computer.

Document prints slowly

Multiple software programs are open

The computer resources are insufficient for the printer to print at its optimum speed. To increase printer speed, close all unnecessary software programs when printing.

Complex documents, graphics, or photos are printing

Documents containing graphics or photos print more slowly than text documents.

Best or Maximum dpi print mode is selected

The printer prints more slowly when Best or Maximum dpi is selected as the print quality. To increase the printer speed, select a different print quality mode.

Printer is in ink-backup mode

The printer might print more slowly if it is in ink-backup mode. For more information, see [Ink-backup mode](#).

To increase the print speed, use two print cartridges in the printer.

Printer software is outdated

Outdated printer software might be installed.

For information about updating the printer software, see [Download printer software updates](#).

Computer does not meet system requirements

If your computer does not have enough RAM or a large amount of free space on the hard drive, the printer processing time will be longer.

1. Verify that the computer hard disk space, RAM, and processor speed meet the system requirements.
The system requirements are listed in the reference guide that came with the printer.
2. Make space available on the hard drive by deleting unwanted files.

Print cartridge problems

- [Incorrect or missing print cartridge](#)
- [Print cartridge is faulty or not installed properly](#)
- ["Print cartridge is in the wrong slot" message](#)
- [Low on ink](#)
- ["Printing in ink-backup mode" message](#)

Incorrect or missing print cartridge

Cause: If the correct print cartridges have not been installed or if the print cartridges are missing, the printer cannot print.

Solution:

To verify and install the correct print cartridges

1. Open the printer cover.
2. Read the selection number on the print cartridge label.

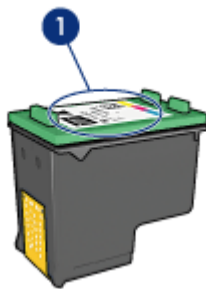

1	Selection number
---	------------------

3. Check the list of print cartridges that can be used in the printer.
 - a. Open the printer [Toolbox](#).
 - b. Click the **Estimated Ink Levels** tab.
 - c. Click the **Print Cartridge Information** button and view the list of print cartridge selection numbers.
The reference guide that came with the printer also shows the print cartridge selection numbers.
4. If the print cartridge selection number is correct, try cleaning the print cartridge. For more information, see [Manually clean print cartridges](#).
5. If the print cartridge has the wrong selection number, install a new print cartridge. For more information, see [Installation instructions](#).
6. Close the printer cover.

If the Print Cartridge Status lights are not flashing, then the problem is fixed.

If one or both Print Cartridge Status lights are flashing, visit HP Technical Support at www.hp.com/support.

Print cartridge is faulty or not installed properly

Cause: The printer cannot print if the print cartridges are faulty, or if they are not installed properly.

Solution:

To resolve the problem

1. Raise the printer cover.
2. Do one of the following:
 - If an error message is displayed on screen, remove the print cartridge that is named in the error message. Go to step 3.
 - If an error message is not displayed, remove and reinstall each print cartridge and close the printer cover.
If the Power light is not flashing, the problem is solved.
If the Power light is flashing, go to step 4.
3. Reinstall the print cartridge and close the printer cover. For more information, see [Installation instructions](#).
If the Power light is not flashing, the problem is solved.
If the Power light is flashing, go to step 4.
4. [Manually clean](#) the print cartridge.
5. Reinsert the print cartridge in the printer and close the printer cover.
If the Power light is still flashing, the print cartridge is faulty and must be replaced.



NOTE: You can print with one print cartridge in ink-backup mode if you do not have a replacement print cartridge available. For more information, see [Ink-backup mode](#).

6. If the Power light continues to flash after replacing the print cartridge, visit HP Technical Support at www.hp.com/support.

"Print cartridge is in the wrong slot" message

Cause: If you receive this error message, the print cartridge is installed in the wrong side of the print cartridge cradle.

Solution: Always install the tri-color print cartridge in the left print cartridge cradle compartment.

Install the black or photo print cartridge in the right print cartridge cradle compartment.

Low on ink

Cause: At least one of the print cartridges is estimated to be low on ink and may need to be replaced soon.

Solution: Have a replacement cartridge on hand to avoid printing interruptions. You do not have to replace the cartridge until print quality deteriorates. If you have installed a refilled or remanufactured print cartridge, or a cartridge that has been used in another printer, the ink level indicator will be inaccurate or unavailable.

For information on how to replace print cartridges, see [Replace print cartridges](#).

"Printing in ink-backup mode" message

Cause: When the printer detects that only one print cartridge is installed, ink-backup mode is initiated. This printing mode lets you print with a single print cartridge, but it slows the printer and affects the quality of printouts.

Solution: If you receive the ink-backup mode message and two print cartridges are installed in the printer, verify that the protective piece of plastic tape has been

removed from each print cartridge. When plastic tape covers the print cartridge contacts, the printer cannot detect that the print cartridge is installed.

To remove plastic tape from a print cartridge

- ▲ Hold the print cartridge so that the copper strips are on the bottom and facing toward the printer, and then carefully remove the plastic tape.

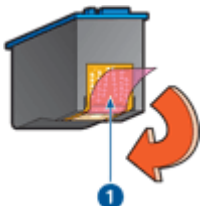

1	Remove plastic tape
---	---------------------

△ **CAUTION:** Do not touch the print cartridge ink nozzles or copper contacts. Touching these parts will result in clogs, ink failure, and bad electrical connections. Do not remove the copper strips. They are required electrical contacts.

Paper problems

- [Paper jam](#)
- [Printer does not feed paper](#)
- [Printer ejects paper](#)
- [Out-of-paper message](#)
- [Printer prints on multiple sheets at once](#)

Paper jam

To clear a paper jam

1. Press the **Resume** button.
If the paper jam does not clear, then go to the next step.
2. Turn off the printer.
3. Disconnect the printer power cord from the electrical outlet.

4. Remove the rear access door. Press the handle to the right, and then pull out the door.

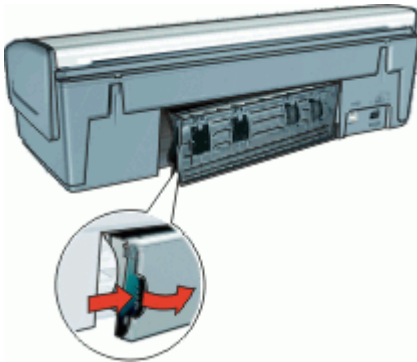

5. Remove any paper that is inside the printer by pulling it out from the back of the printer. If you are printing labels, verify that a label did not become detached from the label sheet while passing through the printer.
6. Replace the rear access door securely.

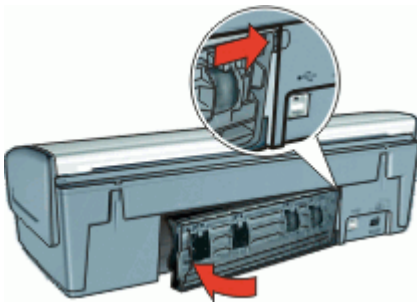

7. If the paper jam cannot be removed from the back of the printer, raise the printer cover, remove the paper jam from the front of the printer, and then lower the cover.

△ **CAUTION:** Remove the paper jam carefully as it is possible to damage the printer when removing paper from the front.

8. Reconnect the printer power cord to the electrical outlet.
9. Turn on the printer, and then press the **Resume** button.
10. Reprint the document.

 **NOTE:** If paper jams occur frequently, try using a heavier paper. See [Printer specifications](#) for paper weight specifications.

Printer does not feed paper

Solution: Try one or more of the following solutions:

- Reduce the number of sheets in the input tray.
 - Remove the paper from the input tray, and then reload it.
 - Use a different type of paper.
-

Printer ejects paper

Solution: If the printer ejects the paper, try one of the following solutions:

- Verify that the protective piece of plastic tape has been removed from the print cartridges.
 - If you are printing a borderless document and the Resume and Print Cartridge Status lights are flashing, you might be trying to print a borderless document with only the black print cartridge installed. When printing a borderless document, always have the tri-color print cartridge and a black or photo print cartridge installed.
-

Out-of-paper message

Follow the appropriate steps for the condition that exists.

- [If the input tray contains paper](#)
- [If the input tray is empty](#)

If the input tray contains paper

1. Verify the following:
 - A sufficient amount of paper is in the input tray (at least ten sheets).
 - The input tray is not overly full.
 - The paper stack is touching the back of the input tray.
2. Slide the paper guide so it fits firmly against the edge of the paper.
3. Press the **Resume** button to continue printing.

If the input tray is empty

1. Load paper in the tray.
2. Press the **Resume** button to continue printing.

Printer prints on multiple sheets at once

If the printer prints on multiple sheets at once, check the following:

- [Paper weight](#)
- [Paper might be loaded improperly](#)

Paper weight

The printer might print on multiple sheets of paper at once if the paper is under the recommended [paper weight](#). Use paper that is within the recommended specifications.

Paper might be loaded improperly

The printer might print on multiple sheets of paper at once if the paper is loaded too far toward the back of the printer or if the paper guide is not positioned firmly against the paper. Reload the paper into the paper tray, pushing the paper until you feel resistance, and then slide the paper guide firmly against the edge of the paper stack.

The printer also might print on multiple sheets if different paper types are loaded in the printer. For example, photo paper might be mixed with plain paper. Empty the paper tray and load only the paper type that is appropriate for the document that you are printing.

Photos do not print correctly

- [Check the paper tray](#)
- [Check the printer properties](#)
- [Colors are tinted or incorrect](#)
- [Horizontal lines appear on a photo](#)
- [Part of the photo is faded](#)

Check the paper tray

1. Verify that the photo paper is placed in the paper tray with the side to be printed on facing down.
2. Slide the paper forward until it stops.
3. Slide the paper guide firmly against the edge of the paper.
Do not press the guide so firmly against the paper that the paper bends or curls.

Check the printer properties

Open the [Printer Properties dialog box](#) and verify the following options:

Tab	Setting
Features	Size: An appropriate paper size Paper Type: An appropriate photo paper Print Quality: Best or Maximum dpi

Colors are tinted or incorrect

Solution: If colors in photos appear tinted or incorrect, follow these steps:

1. Verify that neither print cartridge is low on ink.
For more information, see [View estimated ink levels](#). If neither print cartridge is low on ink, proceed to step 2.
2. [Align](#) the print cartridges.
3. Reprint the photo.
4. If colors continue to appear tinted or incorrect, open the [Printer Properties dialog box](#), click the **Color** tab, and then click the **More color options** button.
5. Adjust the colors by using the **More color options** dialog box.

Horizontal lines appear on a photo

Solution:



If light or dark horizontal lines appear on photos, follow this procedure:

1. [Clean](#) the print cartridges.
2. Reprint the photo.
3. If horizontal lines still occur, perform a [print quality calibration](#).
A black and a tri-color print cartridge must be installed for print quality calibration.
4. Reprint the photo.

 **NOTE:** If you are still not satisfied with the results, replace the print cartridges. For more information, see...

Part of the photo is faded

Fading might occur on the edges or near the edges of a photo.

- [Fading occurs on the edges of a photo](#)
- [Fading occurs near the edges of a photo](#)

Fading occurs on the edges of a photo



Verify that the photo paper is not curled. If the photo paper is curled, place the paper in a plastic bag and gently bend it in the opposite direction of the curl until the paper lies flat. If the problem persists, then use photo paper that is not curled.

For instructions about preventing photo paper from curling, see [Store and handle photo paper](#).

Fading occurs near the edges of a photo



If fading occurs approximately 25 to 63 mm (1.0 to 2.5 inches) from the edge of a photo, try the following solutions:

- Install a [photo print cartridge](#) and a tri-color print cartridge in the printer.
- Open the [Printer Properties dialog box](#), click the **Features** tab, and then set the **Print Quality** to **Maximum dpi**.

Problems with borderless documents

- [Borderless printing guidelines](#)
- [Streaks appear in a light portion of a photo](#)
- [Horizontal lines appear on a photo](#)
- [Image is printed at an angle](#)
- [Ink smears](#)
- [Part of the photo is faded](#)
- [Photo has an unwanted border](#)

Borderless printing guidelines

When printing borderless photos or brochures, follow these guidelines:

- Verify that the paper size that is specified in the **Paper Size** drop-down list on the **Printing Shortcuts** tab matches the size of the paper that is loaded in the paper tray.
- Select the appropriate paper type in the **Paper Type** drop-down list on the **Printing Shortcuts** tab.

- If printing in grayscale, select **High Quality** under **Print in Grayscale** on the **Color** tab.
- Do not print borderless documents in ink-backup mode. Always have two print cartridges installed in the printer when printing borderless documents.
For more information, see [Ink-backup mode](#).

Streaks appear in a light portion of a photo

Solution:

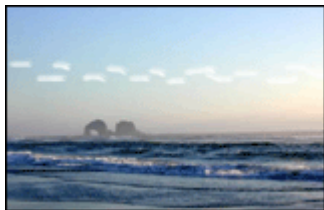

If streaks appear in a light portion of a photo, approximately 63 mm (2.5 inches) from one of the long edges of the photo, try the following solutions:

- Install a [photo print cartridge](#) in the printer.
- Open the [Printer Properties dialog box](#), click the **Features** tab, and then set the **Print Quality** to **Maximum dpi**.

Horizontal lines appear on a photo

Solution:



If light or dark horizontal lines appear on photos, follow this procedure:

1. [Clean](#) the print cartridges.
2. Reprint the photo.

3. If horizontal lines still occur, perform a [print quality calibration](#).
A black and a tri-color print cartridge must be installed for print quality calibration.
 4. Reprint the photo.
-

Image is printed at an angle

Solution:

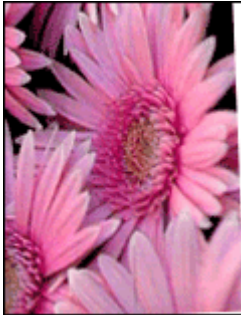

Verify that no problem exists with the source image. For example, if you are printing a scanned image, verify that the image was not crooked when it was scanned.

If the problem is not caused by the source image, follow these steps:

1. Remove all paper from the input tray.
 2. Load the paper correctly in the input tray.
 3. Verify that the paper guide fits firmly against the edge of the paper.
 4. Follow loading instructions for the paper type.
-

Ink smears

Solution: Follow these guidelines if ink smears appear on the back of the photos, or if the paper sticks together:

- Use an HP photo paper.
 - Verify that the photo paper is not curled. If the photo paper is curled, place the paper in a plastic bag and gently bend it the opposite direction of the curl until the paper lies flat.
-

Part of the photo is faded

Fading might occur on the edges or near the edges of a photo.

- [Fading occurs on the edges of a photo](#)
- [Fading occurs near the edges of a photo](#)

Fading occurs on the edges of a photo



Verify that the photo paper is not curled. If the photo paper is curled, place the paper in a plastic bag and gently bend it in the opposite direction of the curl until the paper lies flat. If the problem persists, then use photo paper that is not curled.

For instructions about preventing photo paper from curling, see [Store and handle photo paper](#).

Fading occurs near the edges of a photo



If fading occurs approximately 25 to 63 mm (1.0 to 2.5 inches) from the edge of a photo, try the following solutions:

- Install a [photo print cartridge](#) and a tri-color print cartridge in the printer.
- Open the [Printer Properties dialog box](#), click the **Features** tab, and then set the **Print Quality** to **Maximum dpi**.

Photo has an unwanted border

- [For most paper types](#)
- [For photo paper with a tear-off tab](#)

For most paper types



If the photo has an unwanted border, try one of the following solutions:

- [Align the print cartridges.](#)
- Open the [Printer Properties dialog box](#), click the **Features** tab, and verify that the selected paper size matches both the paper size that the photo is formatted for and the size of the paper that is loaded in the printer.
- Verify that no problem exists with the source image. For example, if you are printing a scanned image, verify that the image was not crooked when it was scanned.
- Verify that the software application you are using supports borderless printing.

For photo paper with a tear-off tab

If the border appears below the tear-off tab, remove the tab.

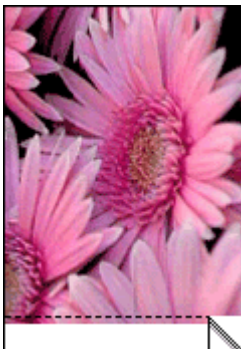

If the border appears above the tear-off tab:

- [Align the print cartridges.](#)
- Verify that no problem exists with the source image. For example, if you are printing a scanned image, verify that the image was not crooked when it was scanned.



Print quality is poor

If you are having problems with print quality, try the solutions in this section and observe the following guidelines:

- Replace refilled or empty cartridges.
- Check the device settings to make sure that the print mode and paper selection is correct for the paper and the task.
For more information, see [Select a paper type](#).
- Print and evaluate a self-test.
For more information, see [Print a test page](#).
If the self-test shows a defect, try the following:
 - Clean the print cartridges automatically. For more information, see [Automatically clean print cartridges](#).
 - If there are ink streaks in your prints, clean the electrical contacts. For more information, see [Manually clean print cartridges](#).
 - Replace the print cartridge. For more information, see [Replace print cartridges](#).
- If the self-test does not show a problem, investigate other causes, such as the image file or software program.

For additional print cartridge troubleshooting, visit the HP Web site at www.hp.com/support.

This section contains the following topics:

- [Faded prints with ink streaks](#)
- [Prints are faded](#)
- [Blank pages print](#)

Faded prints with ink streaks

Solution: If your printed pages faded or if they contain ink streaks, the print cartridges might be low on ink or might need to be cleaned. For more information, see [View estimated ink levels](#) and [Automatically clean print cartridges](#).

Prints are faded

Solution:

- Verify that neither of the print cartridges is low on ink.
For more information, see [View estimated ink levels](#). If a print cartridge is low on ink, consider replacing the print cartridge. For the correct part numbers, see the reference guide that came with the printer.
- Verify that a black print cartridge is installed.
If the black text and images on your printouts are faded, you might be printing with only the tri-color print cartridge. Insert a black print cartridge, in addition to the tri-color print cartridge, for optimal black print quality.
- Verify that the protective piece of plastic tape has been removed from the print cartridges.

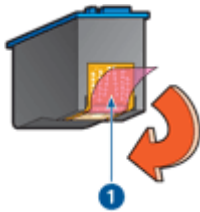

1	Remove plastic tape
---	---------------------

- Consider selecting a higher [print quality](#).
-

Blank pages print

Solution:

- The protective piece of plastic tape might still be attached to the print cartridges. Verify that the plastic tape has been removed from the print cartridges.

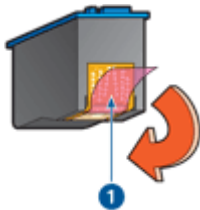

1	Remove plastic tape
---	---------------------

- The print cartridges might be out of ink. Replace one or both empty print cartridges.
For more information, see [View estimated ink levels](#).
 - You might be trying to print a borderless document with only the black print cartridge installed. When printing a borderless document, always have the tri-color print cartridge and a black or photo print cartridge installed.
-

Document is misprinted

- [Text and images are misaligned](#)
- [Document is printed off-center or at an angle](#)
- [Parts of the document are missing or printed in the wrong place](#)
- [Envelope is printed at an angle](#)
- [Document does not reflect the new print settings](#)

Text and images are misaligned

Solution: If the text and images on your printouts are misaligned, then [align](#) the print cartridges.

Document is printed off-center or at an angle

Solution:

1. Verify that the paper is correctly placed in the input tray.
 2. Verify that the paper guide fits firmly against the edge of the paper.
 3. Reprint the document.
-

Parts of the document are missing or printed in the wrong place

Solution: Open the [Printer Properties dialog box](#) and confirm the following options:

Tab	Setting
Features	Portrait or Landscape: Verify the appropriate orientation.
	Size: Verify the appropriate paper size.
	Scale to paper size: Select this option to scale text and graphics to the paper size specified in the corresponding drop-down list.

If parts of the document are still missing, the printer settings might be overridden by the software program print settings. Select the appropriate print settings from within the software program.

Envelope is printed at an angle

Solution:

1. Slide the flap inside the envelope before loading it in the printer.
 2. Confirm that the paper guide fits firmly against the edge of the envelope.
 3. Reprint the envelope.
-

Document does not reflect the new print settings

Solution: The printer settings might differ from the software program print settings. Select the appropriate print settings within the software program.

I pressed the Photosmart Essential button, but nothing happens

Cause: The HP Photosmart Software is not installed.

Solution: Install the HP Photosmart Software that came with the HP Deskjet. If it is installed, restart your computer.

To install the HP Photosmart Software

1. Insert the HP Deskjet CD-ROM into your computer's CD-ROM drive and then start the Setup program.
2. When prompted, click **Install More Software** to install the HP Photosmart Software.
3. Follow the onscreen instructions and the instructions provided in the Setup Guide that came with the HP Deskjet.

 **NOTE:** If you do not have the HP Deskjet CD-ROM, visit the HP online support Web site at www.hp.com/support and download the HP Photosmart Software.

Cause: The HP Deskjet is turned off.

Solution: Turn the HP Deskjet on.

Cause: The computer is turned off.

Solution: Turn the computer on.

Cause: The HP Deskjet is not properly connected to the computer.

Solution: Check the connection from the HP Deskjet to your computer. Verify that the USB cable is securely plugged into the USB port on the back of the HP Deskjet. Make sure the other end of the USB cable is plugged into a USB port on your

computer. After the cable is connected properly, turn the HP Deskjet off and then on again.



For more information on setting up the HP Deskjet and connecting it to your computer, see the Setup Guide that came with the HP Deskjet.

Front USB port problems

- [Images in a connected digital camera do not print](#)
- [Front USB port lights are flashing](#)

Images in a connected digital camera do not print

Cause: There are several reasons why images in a connected digital camera do not print:

- You did not transfer the images from the camera to your computer.
- The digital camera is not in the correct mode for downloading photos.
- The images are not in a supported format.
- You did not select any photos on the camera for printing.

Solution: Verify that you have transferred the images from the camera to your computer. Additionally, verify that the digital camera is saving photos in a file format that the HP Photosmart Software or other photo-printing software program supports.

Before you connect the digital camera to the front USB port on the printer, select some photos on the camera for printing.

For more information on using the HP Photosmart Software, see the HP Photosmart Software Help.

Front USB port lights are flashing

Solution:

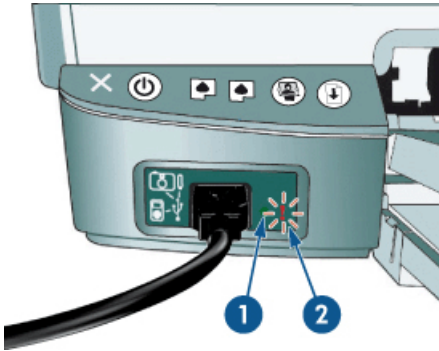

1	Connection light
2	Error light

State of the lights	Task
Connection light and the Error light flash for five seconds	The printer has lost connection with the camera while printing. Check the USB connection.
Connection light is on and the Error light is flashing	The camera is not set to the correct mode for transferring photos. Change the camera mode.
Connection light is off and the Error light is on	An unsupported device, such as a mouse, has been connected to the front USB port. Remove the unsupported device.

If you continue to have problems

If you continue to have problems after investigating the troubleshooting topics, shut down your computer and then restart it.

If you still have questions after restarting your computer, visit HP Technical Support at www.hp.com/support.

For information about the support process, see [HP support](#).

A HP support

- [Ink cartridge warranty information](#)
- [Support process](#)
- [HP support by phone](#)

Ink cartridge warranty information

The HP cartridge(s) warranty is applicable when the product is used in its designated HP printing device. This warranty does not cover HP ink products that have been refilled, remanufactured, refurbished, misused, or tampered with.

During the warranty period the product is covered as long as the HP ink is not depleted and the end of warranty date has not been reached. The end of warranty date, in YYYY/MM/DD format, may be found on the product as indicated:

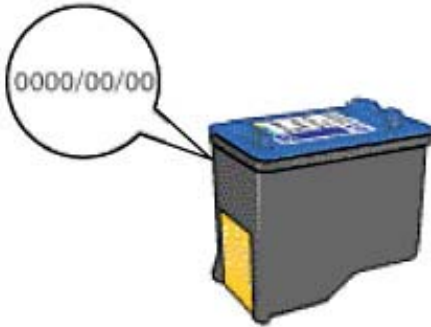

For a copy of the HP Limited Warranty Statement, see the Reference Guide that came with the printer.

Support process

If you have a problem, follow these steps

1. Check the documentation that came with the HP Deskjet.
2. Visit the HP online support Web site at www.hp.com/support. HP online support is available to all HP customers. It is the fastest source for up-to-date device information and expert assistance and includes the following features:
 - Fast access to qualified online support specialists
 - Software and driver updates for your HP Deskjet
 - Valuable HP Deskjet and troubleshooting information for common problems
 - Proactive device updates, support alerts, and HP newsgrams that are available when you register your device
3. For Europe only: Contact your local point of purchase. If your device has a hardware failure, you will be asked to bring it back to your local point of purchase. (Service is provided at no charge during the device limited warranty period. After the warranty period, you will be quoted a service charge.)
4. Call HP support. Support options and availability vary by device, country/region, and language.

HP support by phone

- [Phone support period](#)
- [Placing a call](#)
- [After the phone support period](#)

Phone support period

One year of phone support is available in North America, Asia Pacific, and Latin America (including Mexico). To determine the duration of phone support in Europe, the Middle East, and Africa, go to www.hp.com/support. Standard phone company charges apply.

Placing a call

Call HP support while you are in front of the computer and the HP Deskjet. Be prepared to provide the following information:

- Device model number (located on the label on the front of the device)
- Device serial number (located on the back or bottom of the device)
- Messages that appear when the situation occurs
- Answers to these questions:
 - Has this situation happened before?
 - Can you re-create it?
 - Did you add any new hardware or software to your computer at about the time that this situation began?
 - Did anything else occur prior to this situation (such as a thunderstorm, device was moved, etc.)?

After the phone support period

After the phone support period, help is available from HP at an additional cost. Help may also be available at the HP online support Web site: www.hp.com/support. Contact your HP dealer or call the support phone number for your country/region to learn more about support options.

B Order supplies

You can order HP products, such as recommended types of paper and print cartridges, online from the HP Web site.

This section contains the following topics:

- [Order paper or other media](#)
- [Order print cartridges](#)
- [Order other supplies](#)

Order paper or other media

To order HP papers and other supplies, such as HP Premium Photo Papers, go to www.hp.com/buy/supplies. If prompted, choose your country/region, follow the prompts to select your product, and then click one of the shopping links on the page.

Order print cartridges

For a list of print cartridge numbers, see the printed documentation that came with the HP Deskjet. You can also use the software that came with the HP Deskjet to find out the reorder number for all the print cartridges. You can order print cartridges online from the HP Web site. Additionally, you can contact a local HP reseller to find out the correct print cartridge reorder numbers for your device and purchase print cartridges.

To order HP papers and other supplies, go to www.hp.com/buy/supplies. If prompted, choose your country/region, follow the prompts to select your product, and then click one of the shopping links on the page.

 **NOTE:** Ordering print cartridges online is not supported in all countries/regions. If it is not supported in your country/region, contact a local HP reseller for information about purchasing print cartridges.

To order print cartridges through the HP Solution Center

1. In the HP Solution Center, click the tab that lists your HP Deskjet.
The Shopping Center page is displayed.
2. Click the **Buy online** button.
The Print Cartridge Information page is displayed.
3. Click **Shop Online**.
A privacy information page is displayed.
4. Click **Send**.
The Shop for Supplies window is displayed with a list of compatible cartridges for your printer.

Order other supplies

To order other supplies, such as HP Deskjet software, a copy of the Setup Guide or other printed documentation, or other customer-replaceable parts, call the phone number for your country/region.

Country/region	Number for ordering
Asia Pacific (except for Japan)	65 272 5300
Australia	1300 721 147
Europe	+49 180 5 290220 (Germany)

(continued)

Country/region	Number for ordering
	+44 870 606 9081 (U.K.)
New Zealand	0800 441 147
South Africa	+27 (0)11 8061030
U.S. and Canada	1-800-474-6836 (1-800-HP-INVENT)

To order supplies in other countries/regions not listed in the table, go to www.hp.com/support. If prompted, choose your country/region, and then click **Contact HP** for information on calling for technical support.

C Technical information

- [Printer specifications](#)
- [Environmental product stewardship program](#)
- [Regulatory notices](#)

Printer specifications

The HP Deskjet has the following specifications and requirements.

Physical specifications

Printer dimension (with the tray extended): 144 mm high x 459 mm wide x 480 mm deep (5.67 inches high x 18.07 inches wide x 18.90 inches deep)

Printer weight (without print cartridges): 3.462 kg (7.635 lbs)

Software compatibility

Windows compatible (2000 and XP)

Memory

.5 MB of integrated memory

Minimum system requirements

Operating system ¹	Processor	RAM	Hard disk space
Windows 2000 and XP	Pentium II or equivalent	64 MB	200 MB

1 For information about future operating system releases and support, visit the HP online support Web site at www.hp.com/support.



NOTE: For best printing performance, use a USB 2.0 compatible cable.

Input tray capacity

Plain paper sheets: Up to 100

Output tray capacity

Plain paper sheets: Up to 50

Paper size

For a complete list of supported media sizes, see the printer software.

Paper weights

Letter Paper: 65 to 90 g/m² (16 to 24 lb)

Legal Paper: 70 to 90 g/m² (20 to 24 lb)

Envelopes: 70 to 90 g/m² (20 to 24 lb)

Cards: Up to 200 g/m² (110-lb index maximum)

Photo Paper: Up to 280 g/m² (75-lb index maximum)

Environmental product stewardship program

Hewlett-Packard is committed to providing quality products in an environmentally sound manner. Design for recycling has been incorporated into this product. The number of materials has been kept to a minimum while ensuring proper functionality and reliability. Dissimilar materials have been

designed to separate easily. Fasteners and other connections are easy to locate, access, and remove using common tools. High priority parts have been designed to access quickly for efficient disassembly and repair.

For more information, visit HP's Commitment to the Environment Web site at:

www.hp.com/hpinfo/globalcitizenship/environment/index.html

This section contains the following topics:

- [Paper use](#)
- [Plastics](#)
- [Material safety data sheets](#)
- [Recycling program](#)
- [HP inkjet supplies recycling program](#)
- [Energy consumption](#)
- [Disposal of Waste Equipment by Users in Private Households in the European Union](#)

Paper use

This product is suited for the use of recycled paper according to DIN 19309 and EN 12281:2002.

Plastics

Plastic parts over 25 grams are marked according to international standards that enhance the ability to identify plastics for recycling purposes at the end of product life.

Material safety data sheets

Material safety data sheets (MSDS) can be obtained from the HP Web site at:

www.hp.com/go/msds

Recycling program

HP offers an increasing number of product return and recycling programs in many countries/regions, and partners with some of the largest electronic recycling centers throughout the world. HP conserves resources by reselling some of its most popular products. For more information regarding recycling of HP products, please visit:

For more information regarding recycling of HP products, please visit:

www.hp.com/hpinfo/globalcitizenship/environment/recycle/

HP inkjet supplies recycling program

HP is committed to protecting the environment. The HP Inkjet Supplies Recycling Program is available in many countries/regions, and lets you recycle used print cartridges and ink cartridges free of charge. For more information, go to the following Web site:

www.hp.com/hpinfo/globalcitizenship/environment/recycle/

Energy consumption

This product is designed to reduce power consumption and save natural resources without compromising product performance. It has been designed to reduce total energy consumption both during operation and when the device is not active. Specific information on power consumption may be found in the product specifications.

Disposal of Waste Equipment by Users in Private Households in the European Union



English	<p>Disposal of Waste Equipment by Users in Private Households in the European Union This symbol on the product or on its packaging indicates that this product must not be disposed of with your other household waste. Instead, it is your responsibility to dispose of your waste equipment by handing it over to a designated collection point for the recycling of waste electrical and electronic equipment. The separate collection and recycling of your waste equipment at this time of disposal will help to conserve natural resources and ensure that it is recycled in a manner that protects human health and the environment. For more information about where you can drop off your waste equipment for recycling, please contact your local city office, your household waste disposal service or the shop where you purchased the product.</p>
Français	<p>Évacuation des équipements usagés par les utilisateurs dans les foyers privés au sein de l'Union européenne La présence de ce symbole sur le produit ou sur son emballage indique que vous ne pouvez pas vous débarrasser de ce produit de la même façon que vos déchets courants. Au contraire, vous êtes responsable de l'évacuation de vos équipements usagés et, à cet effet, vous êtes tenu de les remettre à un point de collecte agréé pour le recyclage des équipements électriques et électroniques usagés. Le tri, l'évacuation et le recyclage séparés de vos équipements usagés permettent de préserver les ressources naturelles et de s'assurer que ces équipements sont recyclés dans le respect de la santé humaine et de l'environnement. Pour plus d'informations sur les lieux de collecte des équipements usagés, veuillez contacter votre mairie, votre service de traitement des déchets ménagers ou le magasin où vous avez acheté le produit.</p>
Deutsch	<p>Entsorgung von Elektrogeräten durch Benutzer in privaten Haushalten in der EU Dieses Symbol auf dem Produkt oder dessen Verpackung gibt an, dass das Produkt nicht zusammen mit dem Restmüll entsorgt werden darf. Es obliegt daher Ihrer Verantwortung, das Gerät an einer entsprechenden Stelle für die Entsorgung oder Wiederverwertung von Elektrogeräten aller Art abzugeben (z. B. ein Wertstoffhof). Die separate Sammlung und das Recyceln Ihrer alten Elektrogeräte zum Zeitpunkt ihrer Entsorgung trägt zum Schutz der Umwelt bei und gewährleistet, dass sie auf eine Art und Weise recycelt werden, die keine Gefährdung für die Gesundheit des Menschen und der Umwelt darstellt. Weitere Informationen darüber, wo Sie alte Elektrogeräte zum Recyceln abgeben können, erhalten Sie bei den örtlichen Behörden, Wertstoffhöfen oder dort, wo Sie das Gerät erworben haben.</p>
Italiano	<p>Smaltimento di apparecchiature da rottamare da parte di privati nell'Unione Europea Questo simbolo che appare sul prodotto o sulla confezione indica che il prodotto non deve essere smaltito assieme agli altri rifiuti domestici. Gli utenti devono provvedere allo smaltimento delle apparecchiature da rottamare portandole al luogo di raccolta indicato per il riciclaggio delle apparecchiature elettriche ed elettroniche. La raccolta e il riciclaggio separati delle apparecchiature da rottamare in fase di smaltimento favorisce con la conservazione delle risorse naturali e garantisce che tali apparecchiature vengano rottamate nel rispetto dell'ambiente e della tutela della salute. Per ulteriori informazioni sui punti di raccolta delle apparecchiature da rottamare, contattare il proprio comune di residenza, il servizio di smaltimento dei rifiuti locale o il negozio presso il quale è stato acquistato il prodotto.</p>
Español	<p>Eliminación de residuos de aparatos eléctricos y electrónicos por parte de usuarios domésticos en la Unión Europea Este símbolo en el producto o en el embalaje indica que no se puede desechar el producto junto con los residuos domésticos. Por el contrario, si debe eliminar este tipo de residuos es responsabilidad del usuario entregarlo en un punto de recogida designado de reciclado de aparatos electrónicos y eléctricos. El reciclaje y la recogida por separado de estos residuos en el momento de la eliminación ayudará a preservar recursos naturales y a garantizar que el reciclaje proteja la salud y el medio ambiente. Si desea información adicional sobre los lugares donde puede dejar estos residuos para su reciclado, póngase en contacto con las autoridades locales de su ciudad, con el servicio de gestión de residuos domésticos o con la tienda donde adquirió el producto.</p>
Češtiny	<p>Likvidace vysloužilého zařízení uživateli v domácnosti v zemích EU Tato značka na produktu nebo na jeho obalu označuje, že tento produkt nesmí být likvidován prostým vyhozením do běžného domovního odpadu. Odpovídaté za to, že vysloužilé zařízení bude předáno k likvidaci do stávajících sběrných míst určených k recyklaci vysloužilých elektrických a elektronických zařízení. Likvidace vysloužilého zařízení samostatným způsobem a recyklací napomáhá zachování přírodních zdrojů a zajišťuje, že recyklační procesy způsobem chráním lidské zdraví a životní prostředí. Další informace o tom, kam můžete vysloužilá zařízení předat k recyklaci, můžete získat od úředí místní samosprávy, od společnosti provádějící zprvu a likvidaci domovního odpadu nebo v obchodě, kde jste produkt zakoupili.</p>
Dansk	<p>Bortskaffelse af affaldsudstyr for brugere i private husholdninger i EU Dette symbol på produktet eller på det emballage indikerer, at produktet ikke må bortskaffes sammen med andet husholdningsaffald. I stedet er det dit ansvar at bortskaffe affaldsudstyret ved at aflevere det på det/bestemte indsamlingssted med henblik på genbrug af elektrisk og elektronisk affaldsudstyr. Den separate indsamling og genbrug af det affaldsudstyr på tidspunktet for bortskaffelse af det vil bevare naturlige ressourcer og sikre, at genbrug finder sted på en måde, der beskytter menneskers helbreds samt miljøet. Hvis du vil vide mere om, hvor du kan aflevere dit affaldsudstyr til genbrug, kan du kontakte kommunen, det lokale renovationsvæsen eller den forretning, hvor du købte produktet.</p>
Nederland	<p>Afvoer van afgedankte apparatuur door gebruikers in particuliere huishoudens in de Europese Unie Dit symbool op het product of de verpakking geeft aan dat dit product niet mag worden afgevoerd met het huishoudelijk afval. Het is uw verantwoordelijkheid uw afgedankte apparatuur af te leveren op een aangewezen verzamelpunt voor de verwerking van afgedankte elektrische en elektronische apparatuur. De gescheiden inzameling en verwerking van uw afgedankte apparatuur draagt bij tot het sparen van natuurlijke bronnen en tot het hergebruik van materiaal op een wijze die de volksgezondheid en het milieu beschermt. Voor meer informatie over waar u uw afgedankte apparatuur kunt inleveren voor recycling kunt u contact opnemen met het gemeentehuis, in uw woonplaats, de reinigingsdienst of de winkel waar u het product hebt aangeschaft.</p>
Eesti	<p>Eraajapidamisest kasutatud kõrvaldada avalik eesmärgel kasitlemine Euroopa Liidus Kui tootel või toote pakendil on see sümbol, ei tohi seda toodet viia alla olmejäätiste hulka. Teie kohus on viia tarbetuks muutunud seadme selleks ettenähtud elektrilise ja elektroonilise seadme ühiselt kasitlemise kohta. Ühiselt kasitlemine aitab säästa loodusvarasid ning tagada, et käsitlemine toimub inimeste tervisele ja keskkonnale ohutult. Lisateavet selle kohta, kuhu saate ühiselt kasitlema seadme käsitamiseks viia, saate küsida kohalikest omavalitsustest, olmejäätmete ühiselneemispunktist või kauplustest, kust te seadme ostsite.</p>
Suomi	<p>Hävitettävien laitteiden käsittely kotitalouksissa Euroopan unionissa Tämä tuotteen tai sen pakkausella oleva merkintä osoittaa, että tuotetta ei saa hävittää tavallisten jätteen mukana. Käyttäjän velvollisuus on huolehtia siitä, että hävitettävä laite toimitetaan sähkö- ja elektronikkalaitteiden keräyspisteeseen. Hävitettävien laitteiden erillinen keräys ja kierrätys säästää luonnonvaroja. Näin toimimalla varmistetaan myös, että kierrätyksessä tapahtuu tavalla, joka suojelee ihmisten terveyttä ja ympäristöä. Saat tarvittaessa lisätietoja jätteen kierrätyspakoista paikallisilta viranomaisilta, jätteyhdistyiltä tai tuotteen jälleenmyyjältä.</p>
Ελληνικά	<p>Απορρίψη εξοπλισμού στην οικιακή χρήση στην Ευρωπαϊκή Ένωση Το παρόν σύμβολο στον εξοπλισμό ή την συσκευασία του υποδηλώνει ότι το προϊόν αυτό δεν πρέπει να απορριφθεί μαζί με άλλα οικιακά απορρίμματα. Αντίθετα, ευθύνη σας είναι να απορρίψετε το εξοπλισμό σε ειδικό σημείο, το οποίο σας έχει υποδείξει ο κατασκευαστής ή ο κατάστημα που το αγοράσατε. Η χωριστή συλλογή και η ανακύκλωση των προϊόντων αυτών συμβάλλει στη βελτίωση της υγείας των πολιτών και της προστασίας του περιβάλλοντος. Η χωριστή συλλογή και η ανακύκλωση των προϊόντων αυτών συμβάλλει στη βελτίωση της υγείας των πολιτών και της προστασίας του περιβάλλοντος. Για περισσότερες πληροφορίες σχετικά με το πού μπορείτε να απορρίψετε τις χημικές συσκευές ή τον οικιακό σας, απευθυνθείτε με τις κατά τόπους αρμόδιες αρχές ή με το κατάστημα από το οποίο αγοράσατε το προϊόν.</p>
Magyar	<p>A hulladékgazdálkodás kezeléséről a magánháztartásokban az Európai Unióban Ez a szimbólum, amely a terméken vagy annak csomagolásán van feltüntetve, azt jelzi, hogy a termék nem kezelhető együtt az egyéb háztartási hulladékkal. Az Ön feladata, hogy a készülék hulladékanyagok eljuttatás a olyan kijelölt gyűjtőhelyre, amely az elektronikus hulladékanyagok és az elektronikus berendezések újrahasonosításával foglalkozik. A hulladékanyagok elkülönített gyűjtésére és újrahasonosítására hozzájárul a természet erőitől csak megőrzéshez, egyúttal azt is biztosítja, hogy a hulladék újrahasonosítása az egészséges és környezetbarát módon történjen. A háztartási hulladék-kezelésével foglalkozó vállalatok vagy a termék forgalmazóihoz, ahol leadhata újrahasonosításra a hulladék anyagokat, forduljon a helyi önkormányzatokhoz, a háztartási hulladék-kezelésével foglalkozó vállalatokhoz vagy a termék forgalmazóihoz.</p>
Lietuviškai	<p>Užtvistų atliekų tvarkymas ne nedėginajam švietimui Europos Sąjungos šalyse Šis simbolis už tvirtus vaizdus įpakavimu nurodo, kad šio reikalo nereikia išmesti kartu su kitomis namų ūkio atliekomis. Jūs esate atbildingas pr atliekų tvarkymui ne nedėginajam švietimui, to nododoti norėdama į sąvankas anksčiau, lai tiktu veikta nedėginajam elektriskai an elektroniskai apjunkvui atreždama pirstada. Specialia nedėginajam švietimui sąvankas anksčiau atreždama pirstada palofda dabas rebus nurodo an nodėginajam švietimui, kas sąrga olkviu vėselibu an apkėrdimo vidi. Lai iegutu papildu informacijo par tu, kur atreždama pirstada ir va nogadati nedėginajam švietimui, lūdzia, sazinietes ar vietėjo pašvaldiu, męsi aminciobas akritimu saavėkas anksčiau dienestui vai veiklu, kur į legadama šio švietimui.</p>
Liebuslāhu	<p>Europos Sąjungos vartotojų ir privačių namų ūkio atliekų tvarkymas Šis simbolis ant produkto arba jo pakuočių nurodo, kad produktą negali būti išmesta kartu su kitomis namų ūkio atliekomis. Jūs privalote išmesti savo atliekamą įrangą atitinkamą vietą, į atliekamą elektronikos ir elektros gerbūvimo punktus. Jei atliekamą įrangą bus atskiri surenkama ir perdirbama, bus išsaugomi natūralūs išteklių ir užtikinama, kad įranga būtų apdorojama žmonių sveikatai ir aplinkai taikiu būdu. Išskirtinis atliekų tvarkymas padeda išsaugoti gamtos išteklius ir aplinką, užtikrinant, kad įranga būtų apdorojama žmonių sveikatai ir aplinkai taikiu būdu. Dėl informacijos apie tai, kur galite išmesti atliekamą gerbūvimo švietimą, kreipkitės į atliekamą vietos tarnybą, namų ūkio atliekų švietimo tarnybą arba į paruoštus, kurioje piktote, produktą.</p>
Polski	<p>Utylizacja zużytego sprzętu z uwzględnieniem wyjątków w Unii Europejskiej Symbol ten używany na produkcie lub opakowaniu oznacza, że tego produktu nie należy wyrzucać razem z innymi odpadami domowymi. Użytkownik jest odpowiedzialny za dostarczenie zużytego sprzętu do wyznaczonego punktu gromadzenia zużytych urządzeń elektrycznych i elektronicznych. Gromadzenie osobno i recykling tego typu odpadów przyczynia się do ochrony zasobów naturalnych i jest bezpieczny dla zdrowia i środowiska naturalnego. O dzisie informację na temat sposobu utylizacji zużytych urządzeń można uzyskać od odpowiednich władz lokalnych, w przedsięwzięciach zajmującym się usunięciem odpadów lub w miejscach zakupu produktu.</p>
Português	<p>Descarte de equipamentos por usuários em residências da União Europeia Este símbolo no produto ou na embalagem indica que o produto não pode ser descartado junto com o lixo doméstico. No entanto, é sua responsabilidade levar os equipamentos a serem descartados a um ponto de coleta designado para a reciclagem de equipamentos eletro-eletrônicos. A coleta separada e a reciclagem dos equipamentos no momento do descarte ajudam na conservação dos recursos naturais e garantem que os equipamentos serão reciclados de forma a proteger a saúde das pessoas e o meio ambiente. Para obter mais informações sobre onde descartar equipamentos para reciclagem, entre em contato com o escritório local de sua cidade, o serviço de limpeza pública de seu bairro ou a loja em que adquiriu o produto.</p>
Slovenčina	<p>Postup používateľov v krajinách Európskej únie pri vyhadzovaní zariadenia v domácom používaní do odpadu Tento symbol na produkte alebo na jeho obale znamená, že nesmie byť vyhodnený s iným komunálnym odpadom. Namiesto toho máte povinnosť odviesť toto zariadenie na zbernú miestu, kde sa zabezpečuje recyklácia elektrických a elektronických zariadení. Separovanie a recyklácia zariadenia určeného na odpad pomôže chrániť prírodné zdroje a zabezpečí taký spôsob recyklácie, ktorý bude chrániť ľudské zdravie a životné prostredie. Dašie informácie o separovanom zbere a recyklácii získate na miestnom obecnom úrade alebo v obchodnej sieťi, ktorá predáva vaše komunálne odpady alebo v predajni, kde ste produkt kúpili.</p>
Slovenščina	<p>Načinje z uporabe izdelkov v gospodinjstvih znotraj Evropske unije Znak na izdelku ali embalaži izdelka pomeni, da izdelka ne smete odložiti skupaj z drugimi gospodinjstvenimi odpadki. Odpadno premo ste dolžni oddati na določeno zbirno mesto za recikliranje odpadne elektrone in elektronske opreme. Z ločenim zbiranjem in recikliranjem odpadne elektrone in elektronske opreme bodo pomagal ohraniti naravne vire in zagotovili, da bo odpadna oprema reciklirana tako, da se varuje zdravje ljudi in okolje. Več informacij o mestih, kjer lahko oddate odpadno premo za recikliranje, lahko dobite na občini, v komunalnem podjetju ali trgovini, kjer ste izdelek kupili.</p>

Regulatory notices

- [FCC statement](#)
- [LED indicator statement](#)
- [Notice to users in Korea](#)
- [VCCI \(Class B\) compliance statement for users in Japan](#)
- [Notice to users in Japan about power cord](#)

FCC statement

The United States Federal Communications Commission (in 47 CFR 15.105) has specified that the following notice be brought to the attention of users of this product.

This equipment has been tested and found to comply with the limits for a Class B digital device, pursuant to part 15 of the FCC Rules. These limits are designed to provide reasonable protection against harmful interference in a residential installation. This equipment generates, uses, and can radiate radio frequency energy, and, if not installed and used in accordance with the instructions, may cause harmful interference to radio communications. However, there is no guarantee that interference will not occur in a particular installation. If this equipment does cause harmful interference to radio or television reception, which can be determined by turning the equipment off and on, the user is encouraged to try to correct the interference by one or more of the following measures:

- Reorient or relocate the receiving antenna.
- Increase the separation between the equipment and receiver.
- Connect the equipment into an outlet on a circuit different from that to which the receiver is connected.
- Consult the dealer or an experienced radio/TV technician for help.

This device complies with Part 15 of the FCC Rules. Operation is subject to the following two conditions: (1) this device may not cause harmful interference, and (2) this device must accept any interference received, including interference that may cause undesired operation.

Modifications (part 15.21): The FCC requires the user to be notified that any changes or modifications made to this device that are not expressly approved by HP may void the user's authority to operate the equipment.

For further information, contact the Manager of Corporate Product Regulations, Hewlett-Packard Company, 3000 Hanover Street, Palo Alto, CA 94304, (650) 857-1501.

LED indicator statement

The display LEDs meet the requirements of EN 60825-1.

Notice to users in Korea

사용자 안내문(B급 기기)

이 기기는 비업무용으로 전자파 적합 등록을 받은 기기로서, 주거지역에서는 물론 모든 지역에서 사용할 수 있습니다.

VCCI (Class B) compliance statement for users in Japan

この装置は、情報処理装置等電波障害自主規制協議会（VCCI）の基準に基づきクラスB情報技術装置です。この装置は、家庭環境で使用することを目的としていますが、この装置がラジオやテレビジョン受信機に近接して使用されると受信障害を引き起こすことがあります。
取り扱い説明書に従って正しい取り扱いをして下さい。

Notice to users in Japan about power cord

製品には、同梱された電源コードをお使い下さい。
同梱された電源コードは、他の製品では使用出来ません。

Index

A

- accessibility 2
- after the support period 103
- aligning print cartridges 67

B

- booklet printing 47
- borderless printing 91
- bound two-sided printing 58
- brightness 32
- brochure printing 45
- buttons
 - Cancel 15
 - Photosmart Essential button 13
 - Power button 11
 - Resume button 14

C

- calibrating print quality 68
- calling HP support 103
- CD/DVD tattoo printing 43
- cleaning
 - print cartridges
 - automatically 67
 - print cartridges manually 69
 - printer body 69
- clearing the print queue 81
- color tone 32
- custom paper size 56

D

- default print settings 60
- default printer 60
- digital photos 31
- document is misprinted
 - document is printed off-center or at an angle 98
- document printing 36
- document prints slowly
 - complex documents are printing 82
 - ink-backup mode 82
 - Maximum dpi selected 82
 - multiple programs are open 82

- printer software is
 - outdated 82
 - system requirements 83
- dpi, maximum 55
- duplexing 58

E

- e-mail printing 35
- envelope printing 38
- environment
 - Environmental product stewardship program 106
- Environmental information
 - material safety data sheets 107
 - paper use 107
 - plastics 107
 - recycling program 107
- error messages
 - other errors 74
 - out-of-paper message 88
 - print cartridge errors 73
- estimated ink level 68
- European Union
 - recycling information 108
- Exif Print 32

F

- fast/economical printing 53
- FCC statement 109
- front USB port
 - about 24
 - lights 14, 25
 - printing from 24
 - problems 100

G

- general everyday printing 54
- grayscale printing 56
- greeting card printing 46

H

- hagaki card printing 40
- Hewlett-Packard Company notices 2

- HP Photosmart Share 34
- HP Photosmart Software
 - downloading 63
- HP Photosmart software 34

I

- index card printing 41
- ink
 - low 85
- Ink Status window 62
- ink, removing ink from skin and clothing 69
- ink-backup mode 20
- input tray 17
- installation
 - program stops 74
- installing print cartridges 64
- iron-on transfer printing 50

L

- label printing 42
- LED indicator statement 109
- letter printing 37
- lights
 - all lights are flashing 78
 - front USB port 14
 - Power light 11
 - Power light is flashing 77
 - Print Cartridge Status light 12
 - Print Cartridge Status light is flashing 79
 - Resume light 14
 - Resume light is flashing 78
- low ink 68

M

- maintenance
 - print cartridges 70
 - printer 64
 - printer body 69
- maximum dpi 55

- O**
- order
 - paper 104
 - print cartridges 104
 - Setup Guide 104
 - software 104
 - User Guide 104
- other document printing 35
- other photo projects 34
- output tray 17
- P**
- page order, setting 56
- paper
 - order 104
- paper guide 17
- paper jam 86
- paper trays
 - folding paper trays 18
 - input tray 17
 - output tray 17
 - unfolding paper trays 16
- paper type, selecting 54
- phone support period
 - period for support 103
- photo fix options 31
- photo paper, storing and handling 33
- photo print cartridge 31
- photo printing
 - borderless photos 27
 - photos with a border 29
 - saving money 33
- photo printing problems
 - colors are incorrect 89
 - part of photo is faded 90, 93
 - verifying print settings 89
- photo projects 34
- Photos
 - Online sharing 34
 - Sharing 34
- photos
 - digital 31
 - do not print correctly 89
 - other projects 34
- Photosmart Essential
 - button 23
- placing a call 103
- postcard printing 39
- poster printing 49
- presentation printing 54
- print cartridge problems
 - incorrect print cartridge 83
- Print Cartridge Status lights 12
- print cartridges
 - aligning 67
 - cleaning automatically 67
 - cleaning manually 69
 - faulty 84
 - installing 64
 - low on ink 85
 - maintaining 70
 - not installed properly 84
 - order 104
 - ordering information 68
 - photo print cartridge 31
 - problem message 84
 - selection numbers 64
 - used with the printer 19
- print preview 57
- print quality
 - blank pages print 97
 - calibrating 68
- print queue, clearing 81
- print resolution 55
- print settings
 - advanced color settings 32
 - changing 61
 - default settings 60
- print speed 54
- printer does not feed paper 88
- printer ejects paper 88
- printer features 8
- printer is not printing 80
- printer is stalled 81
- printer lights are flashing 76
- printer maintenance 64
- printer name does not appear 76
- printer prints on multiple sheets
 - at once 88
- printer properties 61
- printer software
 - downloading updates 63
- printer specifications 106
- printer Toolbox 72
- printer troubleshooting 73
- printing
 - 4800 x 1200 optimized dpi 55
 - booklets 47
 - borderless photos 27
 - bound two-sided printing 58
 - brochures 45
 - CD/DVD tattoos 43
 - custom paper size 56
 - digital photos 31
 - documents 36
 - e-mails 35
 - envelopes 38
 - Exif Print 32
 - fast/economical 53
 - from a digital camera 24
 - general everyday printing 54
 - grayscale 56
 - greeting cards 46
 - hagaki cards 40
 - high quality 55
 - index cards and small media 41
 - iron-on transfers 50
 - labels 42
 - letters 37
 - maximum dpi 55
 - multiple pages on single sheet 57
 - other documents 35
 - other photo projects 34
 - photos 27
 - photos with a border 29
 - Photosmart Essential
 - button 23
 - postcards 39
 - posters 49
 - presentation printing 54
 - print preview 57
 - print quality 54
 - print resolution 55
 - print settings 61
 - print speed 54
 - resizing documents 57
 - selecting a paper type 54
 - setting the page order 56
 - software 60
 - tips 52
 - transparencies 44
 - two-sided printing 58
 - with one print cartridge 20
- Printing Shortcuts tab 52
- printing tips 52
- R**
- Real Life Technologies 31
- recycle
 - HP Deskjet 108
 - ink cartridges 107
- regulatory notices
 - FCC statement 109
 - notice to users in Japan (power cord) 110

Index

- notice to users in Japan (VCCI) 109
- notice to users in Korea 109
- WEEE 108
- removing ink from skin and clothing 69
- resizing documents 57

S

- saturation 32
- settings 61
- Share photos with family and friends 34

T

- terms and conventions in manual 2
- test page, printing 52
- Toolbox 72
- transparency printing 44
- troubleshooting
 - all lights are flashing 78
 - borderless printing
 - guidelines 91
 - borderless printing problems 91
 - document does not reflect new print settings 99
 - document prints slowly 82
 - envelope prints at angle 99
 - front USB port problems 100
 - horizontal lines appear on photo 90, 92
 - image prints at angle 93
 - ink smears 93
 - ink streaks 96
 - installation program stops 74
 - misprinted document 98
 - multiple pages print at once 88
 - out-of-paper message 88
 - paper jam 86
 - parts of the document are missing or in wrong place 98
 - photo printing problems 89
 - poor print quality 96
 - Power light is flashing 77
 - print cartridge problem message 84

- Print Cartridge Status light is flashing 79
- print is faded 97
- printer 73
- printer does not feed paper 88
- printer ejects paper 88
- printer is not printing 80
- printer is stalled 81
- printer name does not appear 76
- Resume light is flashing 78
- streaks on photo 92
- text and images are misaligned 98
- unwanted border on photo 94
- two-sided printing 58

U

- Unknown Device message 75
- updates
 - downloading for software 63
 - HP Photosmart Software 63
- USB
 - connecting the printer 22
 - connecting to the printer 22

W

- What's This help 62

